5.0 WARRANTY

ELECTROMATIC Equipment Co., Inc. (ELECTROMATIC) warrants to the original purchaser that this product is of merchantable quality and confirms in kind and quality with the descriptions and specifications thereof. Product failure or malfunction arising out of any defect in workmanship or material in the product existing at the time of delivery thereof which manifests itself within one year from the sale of such product, shall be remedied by repair or replacement of such product, at ELECTROMATIC's option, except where unauthorized repair, disassembly, tampering, abuse or misapplication has taken place, as determined by ELECTROMATIC. All returns for warranty or non-warranty repairs and/or replacement must be authorized by ELECTROMATIC, in advance, with all repacking and shipping expenses to the address below to be borne by the purchaser.

THE FOREGOING WARRANTY IS IN LIEU OF ALL OTHER WARRANTIES, EXPRESSED OR IMPLIED, INCLUDING BUT NOT LIMITED TO, THE WARRANTY OF MERCHANTABILITY AND FITNESS FOR ANY PARTICULAR PURPOSE OR APPLICATION. ELECTROMATIC SHALL NOT BE RESPONSIBLE NOR LIABLE FOR ANY CONSEQUENTIAL DAMAGE, OF ANY KIND OR NATURE, RESULTING FROM THE USE OF SUPPLIED EQUIPMENT, WHETHER SUCH DAMAGE OCCURS OR IS DISCOVERED BEFORE, UPON OR AFTER REPLACEMENT OR REPAIR, AND WHETHER OR NOT SUCH DAMAGE IS CAUSED BY MANUFACTURER'S OR SUPPLIER'S NEGLIGENCE WITHIN ONE YEAR FROM INVOICE DATE.

Some State jurisdictions or States do not allow the exclusion or limitation of incidental or consequential damages, so the above limitation may not apply to you. The duration of any implied warranty, including, without limitation, fitness for any particular purpose and merchantability with respect to this product, is limited to the duration of the foregoing warranty. Some states do not allow limitations on how long an implied warranty lasts but, notwithstanding, this warranty, in the absence of such limitations, shall extend for one year from the date of invoice.

ELECTROMATIC Equipment Co., Inc.
600 Oakland Ave. Cedarhurst, NY 11516—USA
Tel: 1-800-645-4330/ Tel: 516-295-4300/ Fax: 516-295-4399

Every precaution has been taken in the preparation of this manual. Electromatic Equipment Co., Inc., assumes no responsibility for errors or omissions. Neither is any liability assumed for damages resulting from the use of information contained herein. Any brand or product names mentioned herein are used for identification purposes only, and are trademarks or registered trademarks of their respective holders.

Table of Contents

1.0	Introduction	2
2.0	Mounting Procedure	2
3.0	Operating Procedure	3
	3.1 Inserting the material to be measured	
	3.2 Setting the Maximum Tension Detector (optional)	
4.0	Verifying Calibration Accuracy	4
5.0	Maintenance	5
	5.1 Calibration Verification Intervals	
	5.2 Rollers	
	5.3 Cleaning	
6.0	Specifications	6
7.0	Tension Ranges	6
8.0	Dimension Drawings	7
9.0	Warranty	8



The device must not be operated in explosion hazard areas and must not come into contact with aggressive substances.



Tensions that exceed the measuring range of the device by more than 100% may cause a permanent deformation of the measuring spring and must be avoided under any circumstances.

1.0 INTRODUCTION

The CHECK•LINE® model ODT Tension Meter accurately measures running line tensions on a wide variety of yarns, fibers, wires, etc. It's designed for fixed mounting and continuous tension measurement. Threaded mounting holes are provided on the back side and edge of the housing.

2.0 MOUNTING PROCEDURE

Two mounting holes are provided for fastening the tensionmeter on site, see below.

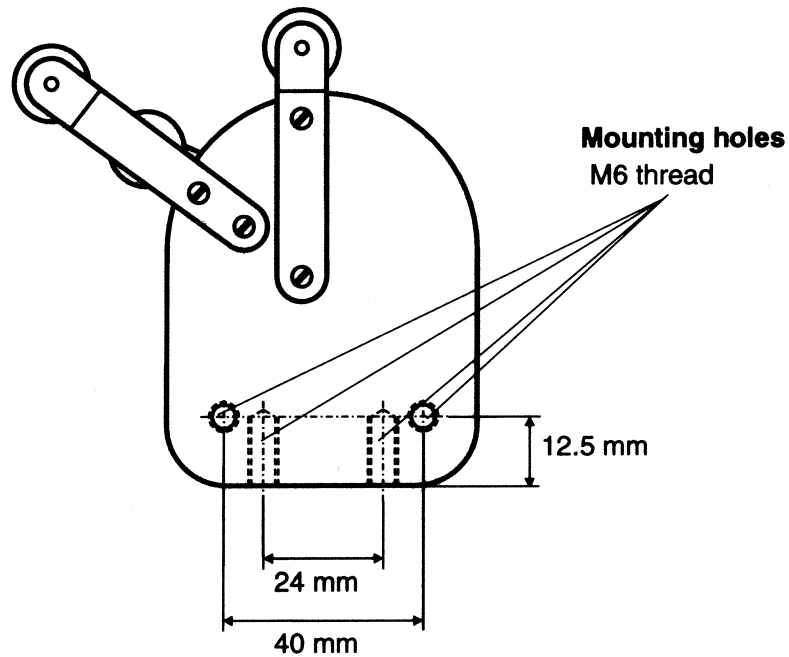

6.0 DIMENSION DRAWINGS

ODT Ranges 10-800

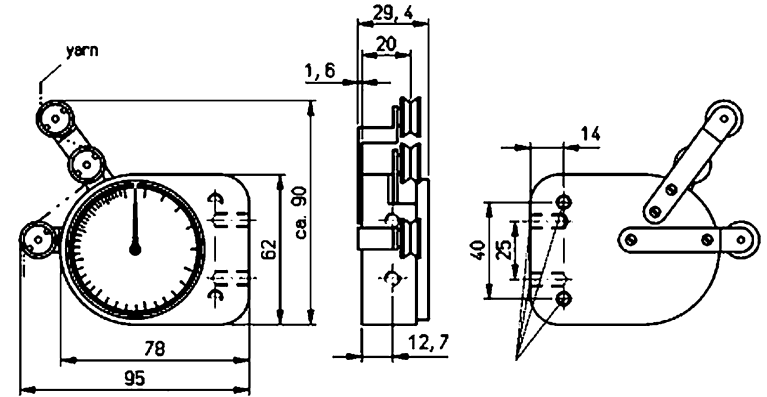

ODT Range 1K

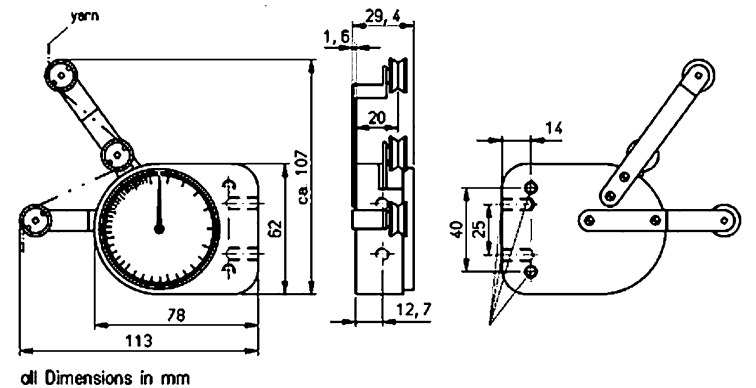

all Dimensions in mm

6.0 SPECIFICATIONS

Calibration	According to factory procedure
Accuracy	± 1% full scale (FS) or ± 1 graduation on scale
Scale diameter	2.28 in (58mm)
Temperature range	50 to 113 °F (10 to 45 °C)
Air humidity	85% RH, max.
Housing material	Chill-cast aluminum
Housing dimensions	3.1 in x 2.45 in x 1.1 in (78 x 62 x 27 mm) — L x W x H
Weight	approx. 0.7 lbs. (300g)

7.0 TENSION RANGES/CALIBRATION MATERIAL

Model	Range (grams)	Calibration Material*
ODT-10	2-10	Faden: 25 tex
ODT-20	2-20	Faden: 25 tex
ODT-30	3-30	Faden: 25 tex
ODT-50	5-50	PA 0.12mm Ø
ODT-70	10-70	PA 0.12mm Ø
ODT-100	10-100	PA 0.12mm Ø
ODT-200	20-200	PA 0.20mm Ø
ODT-300	20-300	PA 0.20mm Ø
ODT-400	40-400	PA 0.20mm Ø
ODT-500	50-500	PA 0.20mm Ø
ODT-800	20-800	PA 0.20mm Ø
ODT-1K	50-1000 grams	PA 0.30mm Ø

* Suitable for 95% of applications. PA = Polyamide Monofilament. If the material to be measured differs significantly from the factory calibration material in diameter, rigidity, shape, etc., we recommend calibration using customer material. For this purpose, a material sample of about 5 m should be supplied. International unit for tension force: 1 cN = 1.02 g = 0.01 N

3.0 OPERATING PROCEDURE

3.1 Inserting the material to be measured

Carefully thread the material to be measured through the measuring roller and roller guides, as shown below. It is important to ensure that the measured material runs smoothly through the roller.

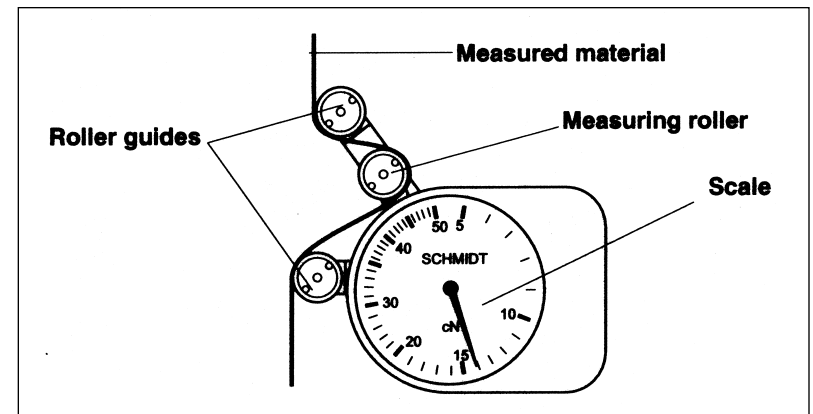

WARNING

To avoid damage do not move the center roller by hand using force.

Are there any other steps that need to be taken before the gauge begins operating?

3.2 Setting the Maximum Tension Detector (optional)

Need copy?

4.0 VERIFICATION OF THE ODT CALIBRATION

All tension meters are calibrated according the factory procedure using standard materials—such as polyamide monofilament (PA)—. The filament sizes are noted in Section 7 on page 6. Any difference in process material size and rigidity from the standard material may cause a deviation of the accuracy.

NOTE: In 95% of all industrial applications the factory calibration has proven to provide the best results and is used for comparative purposes. If the process material differs significant in size, rigidity and shape we recommend special calibration using customer`s sample. For this purpose a material sample 5 m long should be supplied.

Verification Procedure

1. Suspend a known weight that corresponds to the tension to be measured (pay attention to the correct unit of measure) from the process material, vertically, as shown below (Always use a fresh portion of the material to be measured).
2. Before the final check, move the process material slowly up and down to compensate any friction caused by the instrument and thus ensure the repeatability.
3. The tension value should be equal to the value of the suspended weight.

NOTE: If this procedure shows a deviation beyond the allowable tolerance and a reliable operation is no longer allowed, the instrument has to be recalibrated or repaired. For recalibration, return the tension meter to the factory.

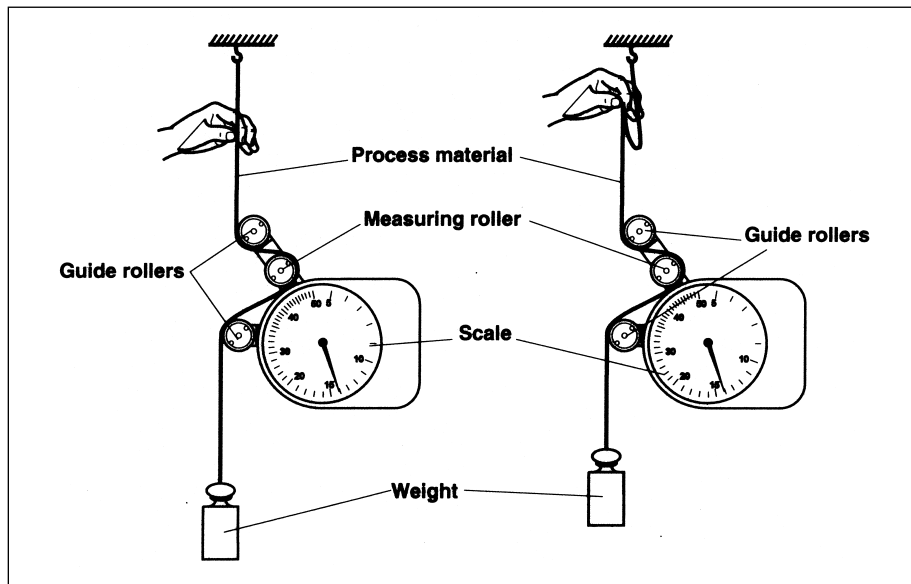

5.0 MAINTENANCE

5.1 Calibration Verification Intervals

Finding the right frequency of calibration accuracy verification depends on several different factors:

- Operating time and load of the tension meter
- Tolerance band defined by the customer
- Changes of the tolerance band compared to previous verifications of calibration

Therefore, the interval between verifications must be determined by the user`s Quality Assurance Department based on the user`s experience. Assuming normal operating time and load as well as careful handling of the tensionmeter, we recommend a verification interval of 1 year.

5.2 Rollers

You should regularly inspect the rollers to assure that they are running easily and smoothly. You can replace the rollers yourself, as necessary. When ordering spare rollers, please indicate the tension meter model and the serial number (on the rear side of the tension meter).

Example of ordering of spare rollers

Model: ODT-20 (on the rear of the tension meter)
Serial number: 230 - 888888 (on the rear of the tension meter)
Standard rollers: Order number R12013

5.3 Cleaning

When cleaning the unit, do not use any aggressive solvents, such as trichloroethylene or similar chemicals. No warranty or liability shall be accepted for damage resulting from improper cleaning.

STATIONARY TENSION METER MODEL ODT



ELECTROMATIC
EQUIPMENT CO., INC.
600 Oakland Ave., Cedarhurst, NY 11516-U.S.A.
TEL: 516-295-4300 • FAX: 516-295-4399