

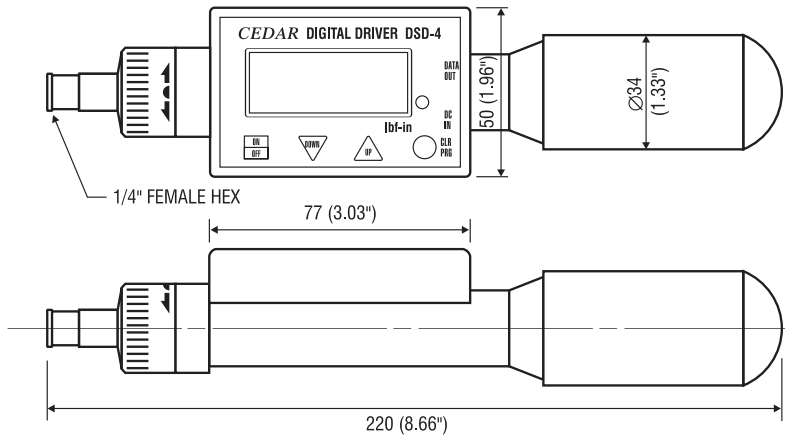

**DIMENSIONS**



# Digital Torque Tester/Screwdriver

**2 YEAR WARRANTY (RESTRICTIONS APPLY)**

Imada, Inc. warrants its products to the original purchaser to be free from defects in workmanship and material under normal use and proper maintenance for two years (one year for adapters, attachments and cables) from original purchase. This warranty shall not be effective if the product has been subject to overload, shock load, misuse, negligence, accident or repairs attempted by others than Imada, Inc.

During the warranty period, we will, at our option, either repair or replace defective products. Please call our customer service department for a return authorization number and return the defective product to us with freight prepaid.

The foregoing warranty constitutes the **SOLE AND EXCLUSIVE WARRANTY**, and we hereby disclaim all other warranties, express, statutory or implied, applicable to the products and/or software, including but not limited to all implied warranties of merchantability, fitness, non-infringement, results, accuracy, security and freedom from computer virus. In no event shall Imada, Inc. and/or its affiliated companies be liable for any incidental, consequential or punitive damages in connection with the use of its products and/or software.

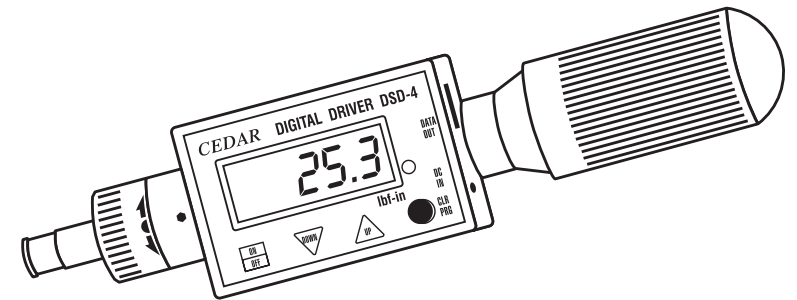

**Model DSD-4**

with ratchet and continuous RS-232 output

# INSTRUCTION MANUAL



## Digital Torque Tester/Screwdriver Model DSD-4

### List of Equipment

- ① Torque Tester with CW and CCW ratchet (1/4" female hex)
- ② AC adapter/charger
- ③ Carrying case

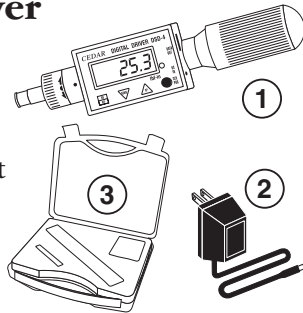

### DSD-4 Digital Torque Tester Ranges

Accuracy  $\pm 0.5\%$  F.S.,  $\pm 1$  LSD

Model	Capacity
DSD-4	0.30 – 35.00 lbf-in (Factory standard)
DSD-4oz	3.0 – 560.0 ofz-in
DSD-4kg	0.30 – 40.00 kgf-cm
DSD-4cN	3.0 – 400.0 N-cm
DSD-4N	0.030 – 4.000 N-m

### Read First: Safety Information

For safety, and for damage avoidance, be sure to read this manual thoroughly. The warranty is only valid when the product is used following the instructions provided within this manual.

- Do not use tester in high temperature, high humidity, or in damp or wet areas.
- Recommended operating temperature is between 0-42°C (32-100°F).
- Do not apply torque exceeding the rated capacity (35 lbf-in), regardless of whether the unit is On or Off. Avoid shock load. Do not use with impact wrenches.
- When charging the battery, be sure to use the provided AC adapter/charger exclusively.
- Do not use lacquer thinner or any solvent to clean the unit.
- Do not disassemble or modify the unit.
- Recommended re-calibration cycle is one (1) year.



**IMPORTANT!** Use the provided CEDAR AC adapter/charger exclusively and plug into the correct AC output. It takes 8 hours to fully recharge. Do not recharge for more than 12 hours. When fully charged, disconnect the AC adapter/charger to avoid overcharging.

In order to avoid high heat, explosion or toxic fumes, please note the following precautions:

1. Be sure to use only the provided AC charger exclusively.
2. Do not plug the charger into unspecified higher voltage.
3. Do not recharge until LOBAT icon appears.

### System Reset

When battery power is completely depleted, the tester may not work even though it has been recharged. In this case, press the System Reset Button.

### RS-232C Serial Output

Output is available in PD, PP and C modes. In PD and PP modes peak data is output when ZERO is pressed or activated by the AUTO ZERO function. In C mode, the gauge outputs data continuously.

RS-232C Signal: 8 data, 2 stop, no parity. Baud Rate: 9600 bps.

### Peak Data Output Format

[CAN] \_ \_ \_ [SO] [value] \_ [SI] [unit] [CR]  
 [CAN]: ASCII control code 24  
 \_: Space (code 32)  
 [SO]: ASCII control code 14  
 [value]: Output data with sign and decimal point. Plus sign represents for CW torque and minus sign for CCW. [Value] always occupy six locations and empty locations will be filled with spaces.  
 [SI]: ASCII control code 15  
 [unit]: N\*m \_ \_ \_ = N·m  
           kgf\*cm = kg·cm  
           lb\*in \_ = lb·in  
 [CR]: ASCII control code 13 (Carriage Return)

### Continuous Output Data Format

[CAN] [value] [CR]



### Storing and Recalling Data from Memory

Memory functions work in PP, PD and C modes. Store up to 300 values in memory. Values are simultaneously output as RS-232 even after memory is full.

1. Measure in PP or PD mode, press CLR/PRG to store peak values. In C mode, the tester outputs data continuously (80 data/sec).
2. To recall a value, press UP or DOWN to select a memory location, the display cycles between location and torque value (i.e. .0.0.1 for first location).

Note: Selecting an invalid location, defaults to measurement mode.

### Clearing Data from Memory

1. **Single Clear:** When a memory value is displayed, press CLR/PRG, then "CLR" displays and blinks 3 times. Press CLR/PRG switch again before "CLR" stops blinking and the memory value is erased.
2. **All Clear:** Press CLR/PRG and DOWN simultaneously until "ALL" is displayed. While "ALL" is blinking, press CLR/PRG again. Display changes to "CLR" and blinks 3 times. Press CLR/PRG again before "CLR" stops blinking and all memory data is erased.

### Downloading Memory Data

1. Press ON/OFF to turn on.
2. Press UP and DOWN switches simultaneously. The display blinks "FA" twice and then displays numbers with decimal points in between (.0.0.1 for first memory location).
3. Press UP or DOWN switch to select the desired beginning memory location and press CLR/PRG to enter. The display blinks "LA" for the ending memory location.
4. Press UP switch or DOWN switch to select the desired ending memory location and press CLR/PRG to enter.
5. Press CLR/PRG switch to download the data. While downloading the data, the display shows "-P-".

Note: By pressing DOWN switch for more than 1 sec, the download function can be terminated.

### Auto Power Off

To maximize the life of the battery, power automatically shuts off after 10 minutes of non-use.

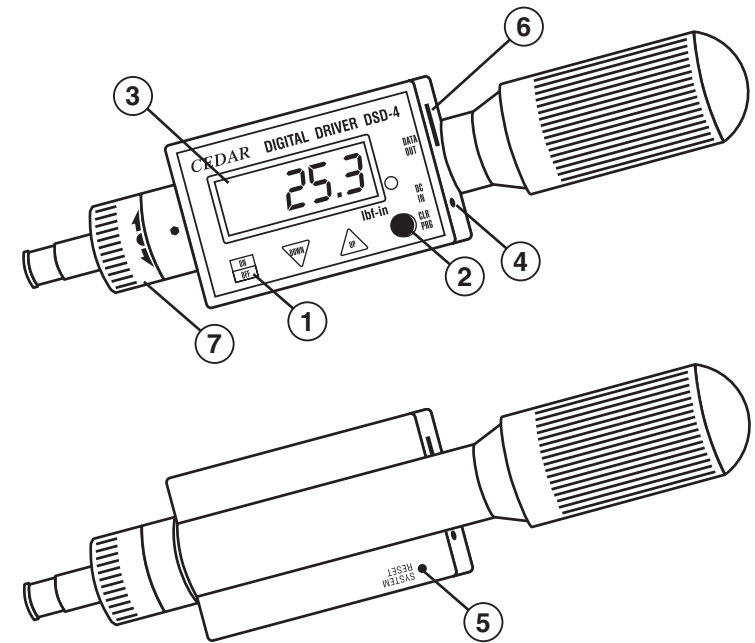

- ① **ON/OFF Switch** Press to turn on, press again to turn off (click once, do not hold). After 10 minutes of non-use the unit shuts off.
- ② **CLR/PRG Switch** To reset display to zero and to store data.
- ③ **LCD Display** Displays torque value as well as low battery icon (LOBAT).
- ④ **AC charger/adaptor receptacle** If LOBAT icon appears, 8-hour battery recharge required.
- ⑤ **System reset button** When the battery has been depleted completely and a recharge has been executed, the system may not yet operate. In this case, press the System Reset Button.
- ⑥ **RS-232 output**
- ⑦ **CW and CCW Ratchet**



## SELECTING RATCHET OPERATION

1. To disable ratcheting, turn the ratchet so the semi circle is in the center position.
2. Enable CW ratcheting operation by turning the ratchet one click counter-clockwise from the center position.
3. Enable CCW ratcheting operation by turning the ratchet one click clockwise from the center position.

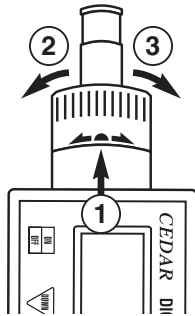

## SELECTING MEASURING MODES

Press ON/OFF to turn on. Hold CLR/PRG for more than 4 seconds. Display cycles GO, PP, PD or C. Select desired measuring mode, which becomes the default mode. Press CLR/PRG to display the measuring mode.

**GO** (Real Time) Display torque transient (no output).

**PP** (Peak) Capture peak torque (peak data output).

**PD** (Peak Down) Capture peak down value (peak data output).

**C** (continuous RS-232 output, 80 data/sec) Display torque transients.

**PROGRAMMING** (to exit programming at any time press OFF) Press ON/OFF to turn on. Press CLR/PRG and UP switches simultaneously and hold for more than 4 seconds. The Green LED lights and one beep sounds, "HI" is displayed, then the High setpoint value. The tester is now ready for the following programming steps.

### 1. High Setpoint (HI)

After "HI" is displayed and then the High setpoint value. Press UP or DOWN switch to select the High setpoint value i.e. 25.0 for 25.0 lbf-in (for lbf-in gauge), then press CLR/PRG to enter.

### 2. Low Setpoint (LO)

After High value is entered, "LO" is displayed and then the Low setpoint value. Press UP or DOWN switch to select the Low setpoint value, then press CLR/PRG to enter.

### 3. Peak Down Minimum and Trigger Point (PdLO)

After Low value is entered, "PdLO" is displayed and then the PdLO



value. Press UP or DOWN switch to select, then press SET to enter. PdLO sets a minimum torque value for Peak Down mode. For example, if "PdLO" value is set at 5.0 lbf-in, only a reading over 5.0 lbf-in will be measured in Peak Down mode.

PdLO also sets the start and stop trigger points for Continuous data output. When torque reaches the PdLO value, the gauge starts to output data and stops if torque falls below the value.

### 4. Batch Counter (CO)

After "PdLO" value is entered, "CO" is displayed and then the batch count number. Press UP or DOWN switch to select (0 to 99), then press CLR/PRG to enter.

Batch counter retains the number of properly torqued fasteners counted in memory even if the tester is turned OFF. Press and hold ON/OFF for more than 1 second to reset.

### 5. Beeper (bp)

After the batch count number is entered, "bp" is displayed and the display shows "On" for beeper set ON, "Off" for beeper set OFF or "FF" for no beep unless over high setpoint. Press UP or DOWN switch to select, then press CLR/PRG to enter.

### 6. Auto Zero Reset (AC)

After Beeper selection is entered, "AC" is displayed and then Auto Zero Reset duration value. Press UP or DOWN to select 0.0C - 0.5C - 1.0C - 1.5C - 2.0C - 2.5C - 3.0C, and press CLR/PRG to enter (0.5C for 0.5 second and 0.0C for MANUAL RESET).

After measuring, Auto Zero automatically resets the tester to "0.0".

### 7. Time (In)

After Auto Zero Reset is entered "In" is displayed and then the Time duration. Press UP or DOWN switch to select (0 to 24 seconds), then press CLR/PRG to enter.

After "In" is entered, "S-" is displayed to confirm programming completion and 0.0 is shown.

After setpoints and batch counter are set, the tester counts the number of properly torqued fasteners (between High and Low setpoint) and beeps three times when completed. If time ("In" value) elapses before reaching the batch count number, a beep sounds to alert to possible mis-tightening or stripped thread.