

8.3 Online Sensor Specifications

Series TS (Models TS1, TSP, TSH, TSL, TSF, TSB1, TSB2)

Calibration:	According to Electromatic factory procedure
Accuracy:	For 10% to 100% of range: ± 1 % full scale
Remainder of range and other calibration material	3% full scale or better
Overload protection	100% of range
Measuring principle	Strain gauge bridge
Measuring roller deflection	0.5 mm, max.
Signal processing	Analog
Output signal:	0 - 1 V DC (standard)
Damping (f_g)	<i>Standard:</i> 30 Hz (other values on request)
Temperature coefficient:	<i>Gain:</i> less than ± 0.01% full scale / °C
Temperature range	10 – 45 °C
Air humidity	85% RH, max.
Power supply	<i>Standard:</i> 12 to 18 VDC (21 mA) (regulated)

TABLE OF CONTENTS

1.0 Introduction	2
1.1 Complete Kit	
2.0 Overview of Indicator	3
3.0 Removing/Replacing Cover	3
4.0 Setup	4
4.1 Setting Decimal Point	
4.2 Setting the Low Alarm Limit	
4.3 Setting the High Alarm Limit	
4.4 Enabling & Disabling Electronic Damping	
5.0 Operation	6
6.0 Calibration	7
6.1 Zero Adjustment	
6.2 Gain Adjustment	
6.3 Checking the Calibration	
7.0 Analog Interface	11
7.1 Changing Analog Output Type	
7.2 Zero and Gain Adjustments	
8.0 Technical Information	15
8.1 TD-1-TE Specifications	
8.2 Pin Assignments	
8.3 On-Line Sensor Specifications	
9.0 Warranty	

1.0 INTRODUCTION

The TD-1-TE Tension Indicator accurately displays tension values calibrated in any unit of measure on a bright LED display, designed for flush panel mounting.

1.1 Complete Kit

- TD-1-TE
- Sensor (as ordered)
- Sensor connecting cable (standard length or as ordered)
- Operating instructions

Photo of complete kit if available

8.0 TECHNICAL INFORMATION

8.1 TD-1-TE Specifications

Digital display	3.5-digit, 7 segment display, height 14.4mm (with tension range setting)
Tension units	cN or daN (depending on sensor)
Damping (f_g)	1 Hz or 40 Hz (selectable)
Output signal	0–10 VDC / $R_{LEAD} \geq 1K \text{ Ohm}$
Output voltage (sensor)	+12 VDC (115 VAC)
Power supply	115 VAC
Current Consumption	0.35 A (0.7A)
Relay output	1A / 230 VAC / 30 VDC break contact
Temperature range	1–45 °C
Air humidity	85% RH, max
Housing	Plastic
Dimensions	96 (L) x 48 (W) x 103 (H) mm
Panel cutout	96 (W) x 48 (H) mm
Weight (approx.)	400 g (net) 1000 g (gross)

8.2 Pin assignments of connectors

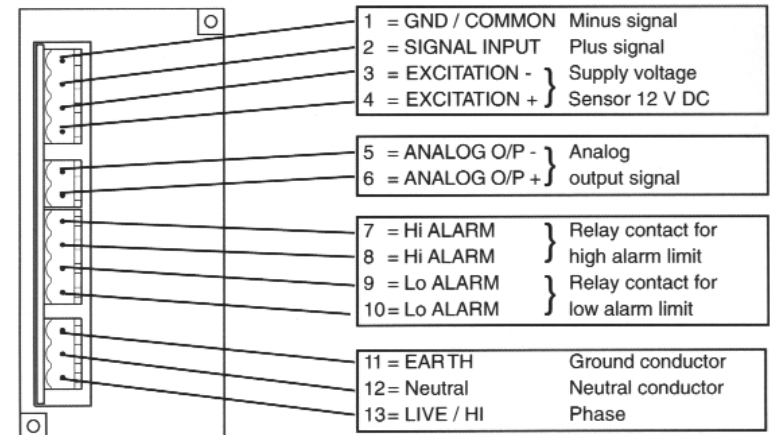

2. Hang a weight that corresponds to 10% of the tension range (pay attention to the correct unit of measure) from the measured material, vertically, as shown in the figure on page 12. (Always use a fresh portion of the material to be measured.)

3. Adjust the potentiometer (13) using a screw-driver with a point width of up to 2mm until the display of the voltmeter connected to the Analog interface reads 0.1 volts

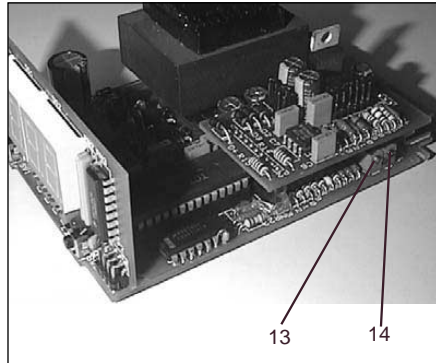

GAIN Adjustment Procedure

1. Perform a Zero adjustment.
2. Thread the process material through the measuring rollers.



WARNING

When threading the process material through the rollers, follow the material path symbol on the front of the sensor. If a force is applied to the middle sensor roller in the incorrect direction, damage could result.

NOTE: Since zero and gain adjustments are always performed statically, the display values may differ under dynamic load.

3. Hang a weight that corresponds to 95% of the tension range (pay attention to the correct unit of measure) from the measured material, vertically as shown in the figure on page 12. (Always use a fresh portion of the material to be measured.)
4. Adjust the potentiometer (14) using a screwdriver (with a point width of up to 2mm) until the display of the voltmeter connected to the Analog interface reads 9.5 volts.

Check the setting and repeat the procedure if necessary.

2.0 OVERVIEW OF THE TD-1-TE INDICATOR

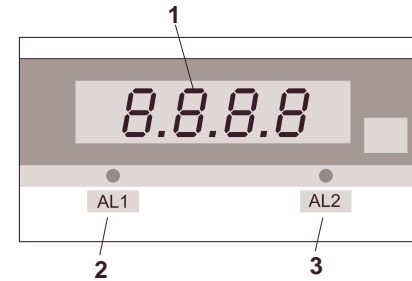

- 1 = Digital display
- 2 = Light emitting diode for low alarm limit
- 3 = Light emitting diode for high alarm limit
- 4 = Decimal point jumper no jumper set of decimal point XXXX

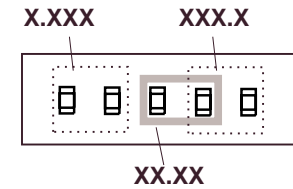
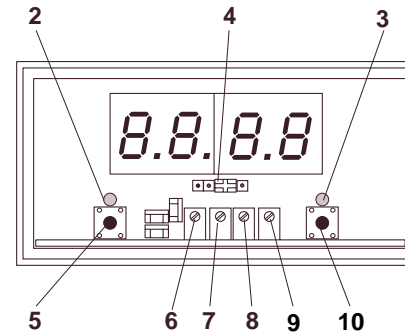

- 5 = Pushbutton for low alarm limit
- 6 = Potentiometer for low alarm limit
- 7 = ZERO potentiometer
- 8 = GAIN potentiometer
- 9 = Potentiometer for high alarm limit
- 10 = Pushbutton for high alarm limit

3.0 REMOVING AND MOUNTING THE FRONT COVER

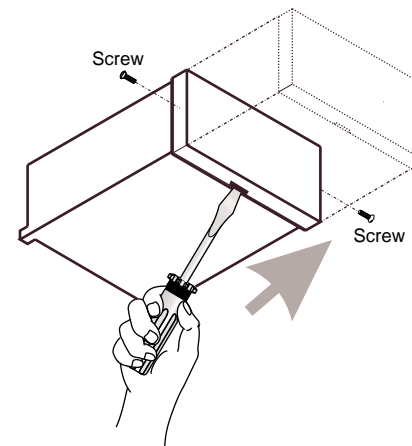

Removing: Remove the two screws. Insert a screwdriver with a point width of 4mm in the slot at the bottom of the housing and carefully push the front cover away from the panel in the direction of the arrow.

Mounting: Carefully push the front cover onto the housing in the opposite direction of the arrow.

4.0 SETUP

4.1 Setting the Decimal Point (Refer to the diagrams in Section 2.0)

The decimal point is factory-set to the supplied sensor. If the indicator unit is supplied without a sensor or after changing to a sensor with a different tension range, the decimal point jumper (4) must be set to the sensor's tension range as follows:

1. Remove the front cover as described in Section 3.0.
2. Set the jumper for decimal point display to the desired position (4)

4.2 Setting the Low Alarm Limit (Refer to the diagrams in Section 2.0)

1. Remove the front cover as described in Section 3.0.
2. Connect the TD-1-TE to the power supply and switch on.
3. Press the pushbutton (5) and use a screwdriver with a point width of 2.5 mm to turn the potentiometer (6) to the desired low alarm limit. Keep the pushbutton (5) depressed while adjusting the pot. At the same time, the digital display (1) shows the set low alarm limit.

4.3 Setting the High Alarm Limit (Refer to the diagrams in Section 2.0)

1. Remove the front cover as described in Section 3.0.
2. Connect the TD-1-TE to the power supply and switch on.
3. Press the pushbutton (10) and use a screwdriver with a point width of 2.5 mm to turn the potentiometer (9) to the desired high alarm limit. Keep the pushbutton (10) depressed while adjusting the pot. At the same time, the digital display (1) shows the set high alarm limit.
4. Then set the front cover back in place as described in Section 3.0.

4.4 Enabling and Disabling Electronic Damping (Refer to the diagrams in Section 2.0)

1. The indicator unit is shipped from the factory with the damping disabled. To enable damping follow this procedure
2. Make sure the TD-1-TE is switched off and all plug connections on the rear side of the device are disconnected.



When power is switched on, a voltage of 115 V is applied to the PC board which is not protected against accidental contact when removed from the housing. For this reason, calibrating the analog output may only be carried out by trained electricians whose qualification for such work has been certified in accordance with local regulations.

2. Connect a voltmeter to the ANALOG interface.
3. Connect the power supply in accordance with the pin assignment of Section 8.2.
4. Switch on the power to the TD-1-TE.
5. Allow approx. 10 minutes for thermal stabilization of the unit.

ZERO Adjustment Procedure

1. Thread the process material through the measuring rollers, following the red marking on the front of the sensor.



When threading the process material through the rollers, follow the material path symbol on the front of the sensor. If a force is applied to the middle sensor roller in the incorrect direction, damage could result.

NOTE: Since zero and gain adjustments are always performed statically, the display values may differ under dynamic load.

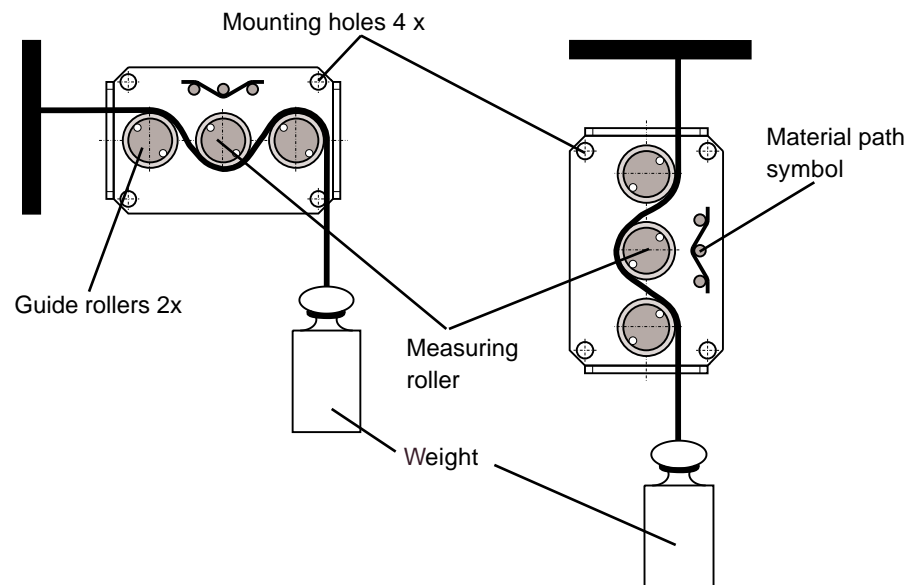

7.2 Zero and Gain Adjustments of the ANALOG Interface

If you change the connected sensor or if you want to fine-tune the Analog interface you need to recalibrate the interface.



Adjustments to the analog output may only be carried out by trained electricians whose qualification for performing such work has been certified in accordance with local regulations.



Only sensors which comply with the specifications given in Section 8.3 may be connected. To avoid random noise and malfunctions, make sure the cable connecting the TD-1-TE with the sensor is not laid parallel to powerlines or highly loaded signal lines, regardless of the type of voltage.

1. Remove the front cover following the instructions outlined in Section 3.0.
2. Loosen the retaining screw (11) at the bottom of the housing.
3. Carefully slide out the PC board from the indicator housing in the direction of the arrow.

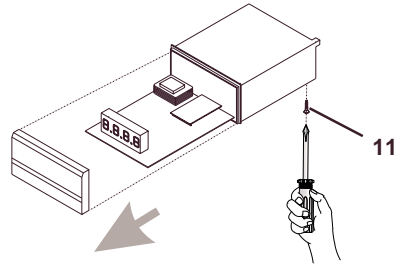

Preparations for Calibration

1. Connect the TD-1-TE with sensor to be used in accordance with the pin assignment illustrated in Section 8.2.



Only sensors which comply with the specifications given in Section 8.3 may be connected. To avoid random noise and malfunctions, make sure the cable connecting the TD-1-TE with the sensor is not laid parallel to power lines or highly loaded signal lines, regardless of the type of voltage.

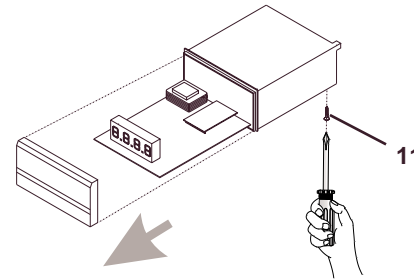

3. Remove the front cover as described in Section 3.0
4. Loosen the retaining screw (11) at the bottom of the housing.
5. Carefully slide out the PC board from the indicator housing in the direction of the arrow.

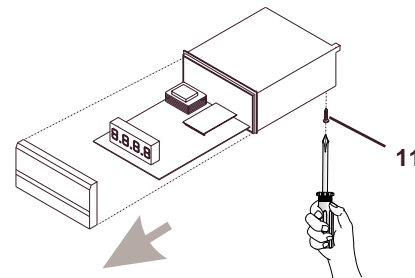
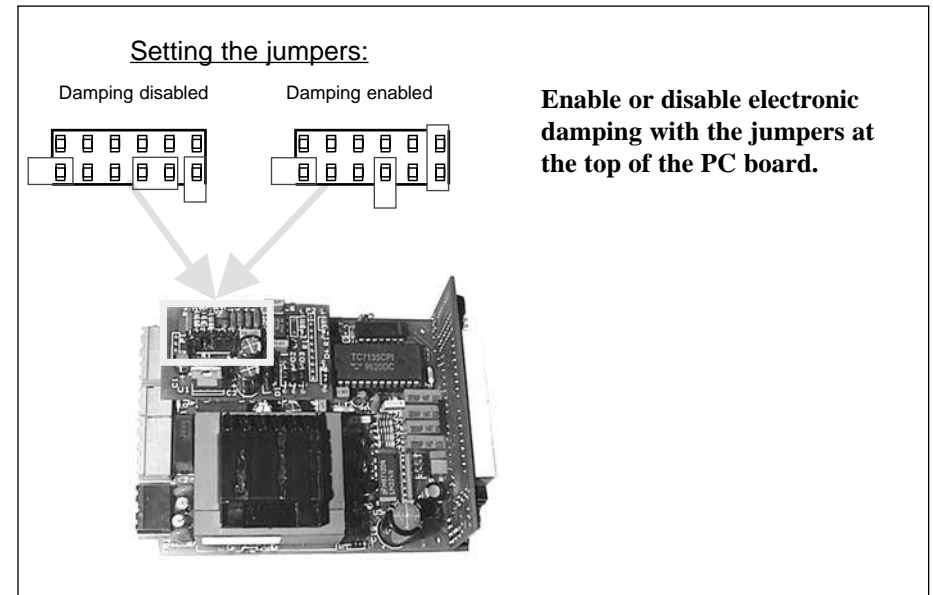

6. Carefully slide the PC board back into the indicator housing in the opposite direction of the arrow.
7. Tighten the retaining screw 11 at the bottom of the housing.
8. Set the front cover back in place as described in Section 3.0.

5.0 OPERATION

1. Install the sensor at the desired measuring location.
2. Connect the TD-1-TE with the supplied sensor as described Section 8.2..



Only sensors which comply with the specifications given in Section 8.3 may be connected.

3. Connect the indicator unit with the power supply as described in Section 8.2 If a longer connecting cable should be required to connect the sensor with the TD-1-TE, note the pin assignment of the sensor's 8-pin connector indicated in the specifications of the sensor's Operating Instructions.



To avoid random noise and malfunctions, make sure the cable connecting the TD-1-TE with the sensor is not laid parallel to power lines or highly loaded signal lines, regardless of the type of voltage.

NOTE: The requirements of the CIE specification are only complied with if the TD-1-TE is equipped and operated with sensors and connecting cables supplied by Electromatic Equipment Company. Certification to the CIE specification does not extend to, and shall be invalid for any other combination. Under no circumstances shall Electromatic Equipment Company be held liable for any resulting damage.

4. Switch on the power to the TD-1-TE. Allow approx. 10 minutes for thermal stabilization.
5. If the material path is other than vertical or if the process material deviates significantly from the Electromatic calibration material, you need to carry a zero and gain adjustment before using, as described in Sections 6.1 and 6.2.
6. Thread the process material through the measuring rollers, following the red marking on the front of the sensor.

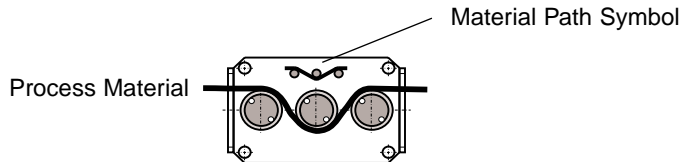

7. The digital display will now show the measured line tension.

7.0 ANALOG INTERFACE

The analog interface is provided for customer signal processing or for connecting a line recorder which conforms to the current industrial standard.

Refer to Sections 8.1 and 8.2 for the specifications for the analog interface.

The TD-1-TE can be set to provide a 4-20 mA or a 0-10 VDC analog output (non-isolated). It is supplied from the factory set for 4-20 mA output. To configure the TD-1-TE for 0-10 VDC output a series of three jumpers must be reconfigured into a different arrangement. To do this the internal PC Board must be removed from the TD-1-TE housing and the small Input Card must be removed from the PC Board to expose the jumpers. Refer to Section 7.1

The analog output is adjusted using the Analog Output Zero & Gain Pots which are located on the right side of the PC Board under the Input Card. The PC Board must be removed from the TD-1-TE housing to perform this adjustment, but the Input Card does not have to be removed.

7.1 Changing Analog Output Type

To obtain access to the Analog Output Adjustment Pots the PC Board must be removed from the TD-1-TE housing.

1. Unplug all connectors on the rear side of the unit (sensor, power, etc.)
2. Remove the front cover as performed during calibration.
3. Remove the PC board retaining screw located at the bottom of the housing.
4. Carefully slide out the entire internal assembly.
5. Remove the Input Card by grasping it by its edges and pulling straight up. The three jumpers will be adjacent to the Analog Output Adjustment Pots
6. Carefully remove all three jumpers and re-configure them as shown in the diagram.

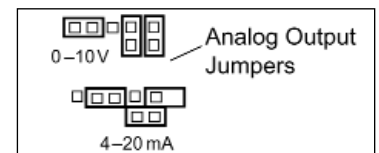
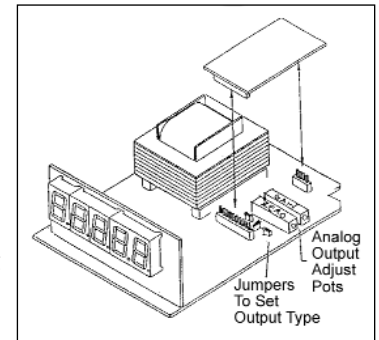
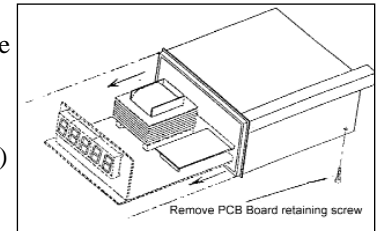

NOTE: Since zero and gain adjustments are always performed statically, the display values may differ under dynamic load.

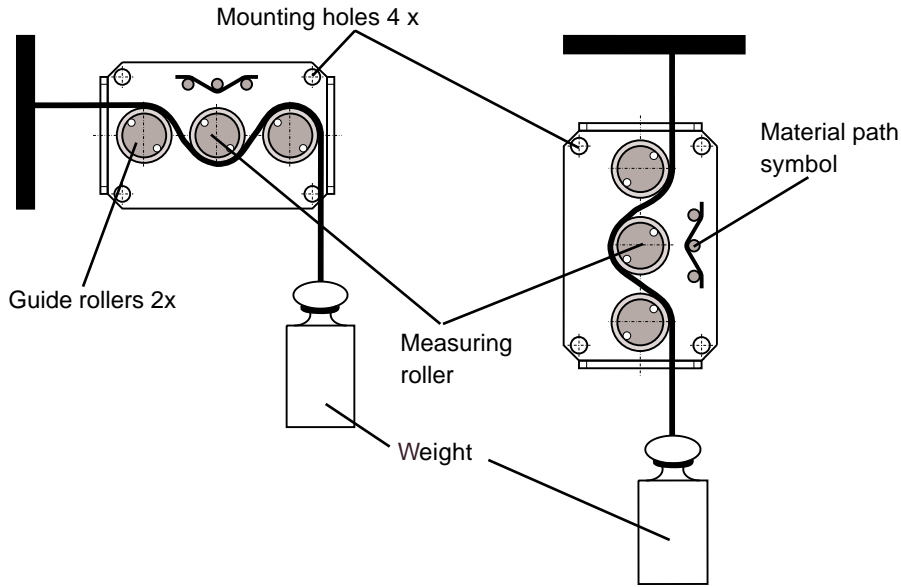

3. Hang a weight that corresponds to the tension to be measured (pay attention to the correct unit of measure) from the measured material, vertically, as shown in the figure above (Always use a fresh portion of the material to be measured.)

The tension value on the digital display should be equal to the value of the suspended weight.

If this procedure shows a deviation beyond the allowable tolerance and a reliable operation is no longer allowed, the instrument has to be readjusted, following the directions in Section 6.3.

6.0 CALIBRATION

All tension meters are calibrated with standard material—such as polyamide-monofilament (PA)—according to the Electromatic factory procedure; the material path is vertical. Any difference in process material size and rigidity from the standard material may cause a deviation of the accuracy.

In 95% of all industrial applications, the Electromatic calibration has been proven to provide the best results and is used for comparative purposes.

If required, you can also operate the sensors with a material path other than vertical. Should the process material differ significantly from the Electromatic calibration material in size, rigidity and shape, we recommend special calibration using customer-supplied material. In the case of a material path other than vertical or special calibration using customer-supplied material, you need to carry out static **zero** and **gain adjustment** once again as described in Sections 6.1 and 6.2.



When threading the process material through the rollers, follow the material path symbol on the front of the sensor. If a force is applied to the middle sensor roller in the incorrect direction, damage could result.

NOTE: Since zero and gain adjustments are always performed statically, the display values may differ under dynamic load.

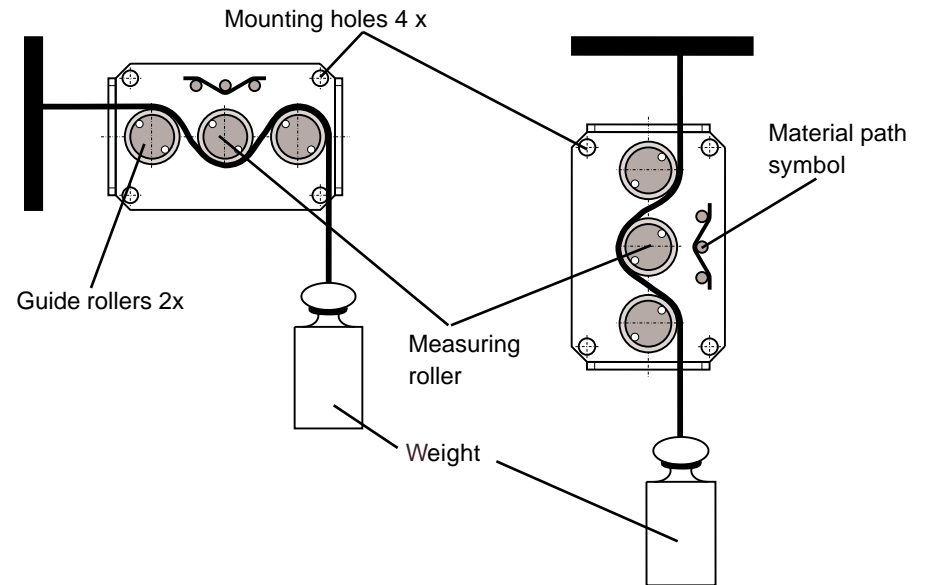

6.1 Zero Adjustment

Requirements:

- Decimal point set as described in Section 4.0.
- Front cover removed as described in Section 3.0.
- Sensor mounted at measuring location.



Only sensors which comply with the specifications given in Section 8.2 may be connected. To mold random noise and malfunctions, make sure the cable connecting the TD-1-TE with the sensor is not laid parallel to power lines or highly loaded signal lines, regardless of the type of voltage.

NOTE: The requirements of the CIE specification are only complied with if the TD-1-TE is equipped and operated with sensors and connecting cables supplied by Electromatic Equipment Company. Certification to the CIE specification does not extend to, and shall be invalid for any other combination. Under no circumstances shall Electromatic Equipment Company be held liable for any resulting damage.

Procedure:

1. Connect the TD-1-TE with supplied sensor as shown in Section 8.2
2. Switch on the TD-1-TE and allow approx. 10 minutes for thermal stabilization of the unit
3. Thread the process material through the measuring rollers, following the red marking on the front of the sensor.
4. Hang a weight that corresponds to 10 % of the tension range (pay attention to the correct unit of measure) from the measured material, vertically as shown on page 7. (Always use a fresh portion of the material to be measured.)
5. Adjust the potentiometer ZERO (#7, page 3) using a screwdriver with a point width of up to 2 mm until the tension value on the digital display is equal to the value of the suspended weight.

For example:

Sensor Model TS - 200: Weight 20 cN = Display 20.0 cN

6. Set the front cover back in place as described in Section 3.0.

6.2 Gain Adjustment

1. Perform a Zero adjustment carried out as described in Section 6.1.
2. Thread the process material through the measuring rollers.
3. Hang a weight that corresponds to 95 % of the tension range (pay attention to the correct unit of measure) from the measured material, vertically as shown on page 7. (Always use a fresh portion of the material to be measured.)
4. Adjust the potentiometer GAIN (#8, page 3) using a screwdriver (with a point width of up to 2mm until the tension value on the digital display (#1) is equal to the value of the suspended weight.

For example:

Sensor Model TS - 200: Weight 190 cN = Display 190.0 cN

5. Check the calibration with a fresh portion of the process material and repeat the adjustments if required, following the directions in Section 6.0.
6. Set the front cover back in place as described in Section 3.0.

6.3 Checking the Calibration

For general information, refer to Section 6.0.

Requirements:

- Decimal point set as described in Section 4.0.
- Front cover removed as described in Section 3.0.
- Sensor mounted at measuring location.
- TD-1-TE connected with supplied sensor as described in Section 8.2.

Procedure:

1. Switch on the power to the TD-1-TE. Allow Approx. 10 minutes for thermal stabilization of unit.
2. Thread the process material through the measuring rollers, following the red marking on the front of the sensor

When threading the process material through the rollers, follow the material path symbol on the front of the sensor. If a force is applied to the middle sensor roller in the incorrect direction, damage could result.



9.0 WARRANTY

ELECTROMATIC Equipment Co., Inc. (ELECTROMATIC) warrants to the original purchaser that this product is of merchantable quality and confirms in kind and quality with the descriptions and specifications thereof. Product failure or malfunction arising out of any defect in workmanship or material in the product existing at the time of delivery thereof which manifests itself within one year from the sale of such product, shall be remedied by repair or replacement of such product, at ELECTROMATIC's option, except where unauthorized repair, disassembly, tampering, abuse or misapplication has taken place, as determined by ELECTROMATIC. All returns for warranty or non-warranty repairs and/or replacement must be authorized by ELECTROMATIC, in advance, with all repacking and shipping expenses to the address below to be borne by the purchaser.

THE FOREGOING WARRANTY IS IN LIEU OF ALL OTHER WARRANTIES, EXPRESSED OR IMPLIED, INCLUDING BUT NOT LIMITED TO, THE WARRANTY OF MERCHANTABILITY AND FITNESS FOR ANY PARTICULAR PURPOSE OR APPLICATION. ELECTROMATIC SHALL NOT BE RESPONSIBLE NOR LIABLE FOR ANY CONSEQUENTIAL DAMAGE, OF ANY KIND OR NATURE, RESULTING FROM THE USE OF SUPPLIED EQUIPMENT, WHETHER SUCH DAMAGE OCCURS OR IS DISCOVERED BEFORE, UPON OR AFTER REPLACEMENT OR REPAIR, AND WHETHER OR NOT SUCH DAMAGE IS CAUSED BY MANUFACTURER'S OR SUPPLIER'S NEGLIGENCE WITHIN ONE YEAR FROM INVOICE DATE.

Some State jurisdictions or States do not allow the exclusion or limitation of incidental or consequential damages, so the above limitation may not apply to you. The duration of any implied warranty, including, without limitation, fitness for any particular purpose and merchantability with respect to this product, is limited to the duration of the foregoing warranty. Some states do not allow limitations on how long an implied warranty lasts but, notwithstanding, this warranty, in the absence of such limitations, shall extend for one year from the date of invoice.

ELECTROMATIC Equipment Co., Inc.
600 Oakland Ave. Cedarhurst, NY 11516—USA
Tel: 1-800-645-4330/ Tel: 516-295-4300/ Fax: 516-295-4399

Every precaution has been taken in the preparation of this manual. Electromatic Equipment Co., Inc., assumes no responsibility for errors or omissions. Neither is any liability assumed for damages resulting from the use of information contained herein. Any brand or product names mentioned herein are used for identification purposes only, and are trademarks or registered trademarks of their respective holders

TD-1-TE

WITH TE TENSION SENSORS

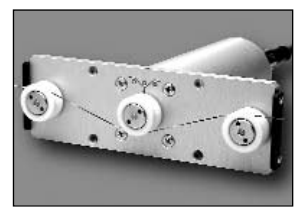
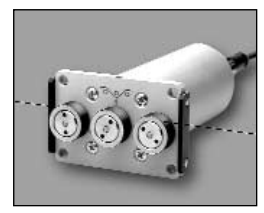
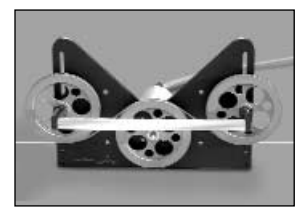

ELECTROMATIC
EQUIPMENT CO., INC.
600 Oakland Ave., Cedarhurst, NY 11516-U.S.A.
TEL: 516-295-4300 • FAX: 516-295-4399