

Tension Sensor RFS[®] 150 E

with integrated Precision Measurement Amplifier

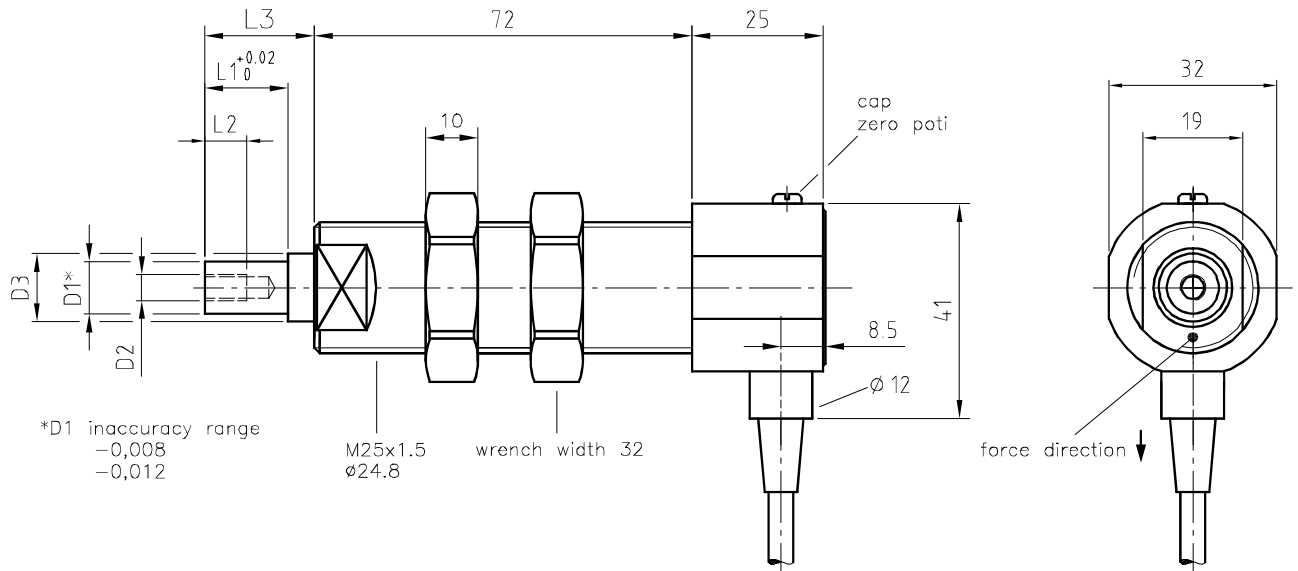

BA 561742-E

Nominal force [N]						Bearing journal ø [mm]		
1-2	5	10	20	30	40	5	8	10
50	60	100	200	300	400		8	10
500	600	1000						10

Bearing journal ø [mm]	Dimensions [mm]				
	D1	L1	D2	L2	D3
5	9,9	M3	6	7	12,9
8	11,9	M4	6	10	15,9
10	15,9	M5	8	13	20,9

Order code

RFS[®] 150 E / 0200 / 10 / 3 / O / 10

Sensor type

Nominal force [N] ————

Bearing journal ø [mm] ————

Cable length [m] ————

Standard: **3**

Option: required length

Connection type ————

Standard: open ends **O**

Option: connector **S**

Output signal ————

Standard: 0 to 10V **10**

Option: 0 to 20mA **0-20**

 4 to 20mA **4-20**

The listed dimensions are corresponding to the product standard.

> Do you require customized variants of dimensions, adapters for bearing journal or guide pulleys ?

> We would be pleased to forward a special quotation !

611780

Technical Data - Tension Sensor RFS® 150 E

Type of sensor	RFS® 150 E	
Rated measuring ranges available (F_N)	N	0 - 1 to 0 - 1000
Accuracy class		0,5
Power supply	V DC	20 to 28
Quiescent current (without load)	mA	ca. 36
Output		
- voltage	V	0 to ± 10 , $R_L \geq 10k\Omega$
- OPTION: current output	mA	0/4 to 20, admissible load 0 to 300Ω
Ultimate frequency (-3dB) output signal	Hz	70
Adjustment range zero	% F_N	± 45
Rated temperature range	$^{\circ}C$	+5 to +50
Operational temperature range		
- sensor	$^{\circ}C$	-10 to +50
- connection cable	$^{\circ}C$	-30 to +80
Storage temperature range	$^{\circ}C$	-30 to +70
Reference temperature	$^{\circ}C$	+23
Temperature influence per 10 $^{\circ}C$		
- on the zero point	% F_N	$< \pm 0,2$
- on the calibration	% F_N	$< \pm 0,15$
Creep after 30 minutes	% F_N	$< \pm 0,05$
Linear output signal up to	% F_N	approx. 125
Mech. overload protection takes effect at	% F_N	approx. 140
Overload protected ¹	% F_N	400 to 800, depending on nominal force
Ultimate side load	% F_N	200
Typ. deflection at nominal force	mm	$0,07 \pm 20\%$
Typ. resonant frequency of the measuring cell	kHz	1 to 3, depending on nominal force
Weight	g	approx. 500
Connection cable	robust, flexible, shielded 4 x 0,14mm ² , cable \varnothing 4,5mm, 3m long, open ends with splices, sheath special PVC	
Sensor covering and nuts	stainless steel	
System of protection	IP 50	

¹ radial incoming force without additional bending or tilting moment

611781

Connections

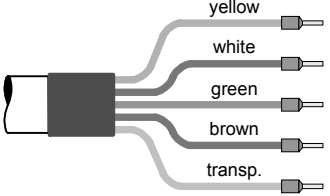
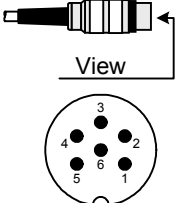
Standard: connection type „O“	Option: connection type „S“																								
 <table border="1"> <tr> <td>+24V DC</td> <td rowspan="2">Power supply</td> </tr> <tr> <td>↓ GND 24V</td> </tr> <tr> <td>Signal</td> <td rowspan="2">Output</td> </tr> <tr> <td>⊥ GND signal</td> </tr> <tr> <td>Shield (not connected to housing)</td> <td></td> </tr> </table>	+24V DC	Power supply	↓ GND 24V	Signal	Output	⊥ GND signal	Shield (not connected to housing)		 <table border="1"> <tr> <td>1</td> <td>+24V DC</td> <td rowspan="2">Power supply</td> </tr> <tr> <td>2</td> <td>↓ GND 24V</td> </tr> <tr> <td>3</td> <td>Shield (not connected to housing)</td> <td></td> </tr> <tr> <td>4</td> <td>⊥ GND signal</td> <td rowspan="2">Output</td> </tr> <tr> <td>5</td> <td>Signal</td> </tr> <tr> <td>6</td> <td>Reserved</td> <td></td> </tr> </table>	1	+24V DC	Power supply	2	↓ GND 24V	3	Shield (not connected to housing)		4	⊥ GND signal	Output	5	Signal	6	Reserved	
+24V DC	Power supply																								
↓ GND 24V																									
Signal	Output																								
⊥ GND signal																									
Shield (not connected to housing)																									
1	+24V DC	Power supply																							
2	↓ GND 24V																								
3	Shield (not connected to housing)																								
4	⊥ GND signal	Output																							
5	Signal																								
6	Reserved																								

611782

Technical execution subject to change without prior notice.
Reproduction - in whole, in part or in translation - is prohibited.