



TT-3000 Torque Tester

The TT-3000 Series Torque Testers are designed specifically for the needs of today's production facilities.

These powerful and versatile systems accommodate most testing requirements at an outstanding cost benefit. They are perfect for testing click, dial, and digital wrenches, plus most power tools including impulse and DC electric.

Storage memory allows 999 data points to be saved to the unit for review, or transmitted to a local printer or PC via the standard RS232 interface. The unique keylock feature enables tamper-proof operation. High and low limits are easily set, and a panel mounted LED provides visual notification to the user when torque reaches these limits. Systems include dedicated internal transducers in vertical or horizontal configurations, and rundown fixtures for power/pulse tool testing.



- Bidirectional accuracy of $\pm 0.5\%$ of indicated reading
- Eight selectable engineering units: Oz.in., Lb.in., Lb.ft., Nm, cNm, KgCm, gfCm, Kgfm
- 3 modes of operation: Track, Peak and 1st Peak
- NiMH rechargeable batteries provide 8-10 hours of continuous use
- Joint Simulator supplied with all 1/4", & 3/8" drives, optionally available on 1/2", 3/4" & 1" drives.
- RS-232 Output
- Selectable power tool filtering speeds: 125Hz, 250Hz, 500Hz, 1000Hz, 1500Hz and 2000Hz
- Includes NIST Calibration Certificate with Data

**Designed specifically for
production facility use**



The TT-3000 Series accommodates most testing requirements at an outstanding cost benefit.

Specifications

Calibrated Range	10-100% Full Scale, bi-directional (<i>Standard</i>)
Extended Range	(<i>ER Option</i>) 5-100% Full Scale, bi-directional
Accuracy	±0.5% of indicated (within calibrated range)
Resolution	4 Active Digits
Overload Protection	200% Full Scale bi-directional
Operating Modes	Track, Peak, 1st Peak
Filtering	Selectable; 125Hz, 250Hz, 500Hz, 1000Hz, 1500Hz and 2000Hz
Memory	Data storage of up to 999 readings
Data Output	RS-232
Display	2.44 x 2.44 in (62 x 62mm) backlit LCD
Alarm Limits	Panel Mounted LED for Visual Alarm Limits
Power	NiMH rechargeable batteries provide 8-10 hours continuous use
Weight	6-9 lbs (2.7-4 kg), depends on number of transducers
Operating Temp	32 - 120 °F (0-50 °C)
Warranty	1 Year
Calibration Certificate	Includes NIST Traceable calibration certificate with data
Standard Accessories	Joint Simulator for 1/4" & 3/8" drives, AC adapter/charger
Optional Accessories	Joint Simulators for 1/2", 3/4" & 1" Transducers, Extended Range "ER" Option

Model	Range	Drive Size	Run-Down Fixture
TT-3001	10 – 100 Oz-In	1/4" Sq. Dr	Included
TT-3011	1 – 10 Lb-In	1/4" Sq. Dr.	Included
TT-3002	20 – 200 Oz-In	1/4" Sq. Dr.	Included
TT-3012	2.5 – 25 Lb-In	1/4" Sq. Dr.	Included
TT-3005	5 – 50 Lb-In	1/4" Sq. Dr.	Included
TT-3010	10 – 100 Lb-In	1/4" Sq. Dr.	Included
TT-3015	15 – 150 Lb-In	1/4" Sq. Dr.	Included
TT-3025	25 – 250 Lb-In	3/8" Sq. Dr.	Included
TT-3050	50 – 500 Lb-In	3/8" Sq. Dr.	Included
TT-3075	75 – 750 Lb-In	3/8" Sq. Dr.	Included
TT-30100	100 – 1000 Lb-In	3/8" Sq. Dr.	Included
TT-3100	10 – 100 Lb-Ft	1/2" Sq. Dr.	Optional
TT-3150	15 – 150 Lb-ft	1/2" Sq. Dr.	Optional
TT-3250	25 – 250 Lb-Ft	1/2" Sq. Dr.	Optional

Joint Simulators/Run Down Fixtures

Required for accurate torque measurement for power-driven torque controlled tools (electric, hydraulic or pneumatic).



Dimensions

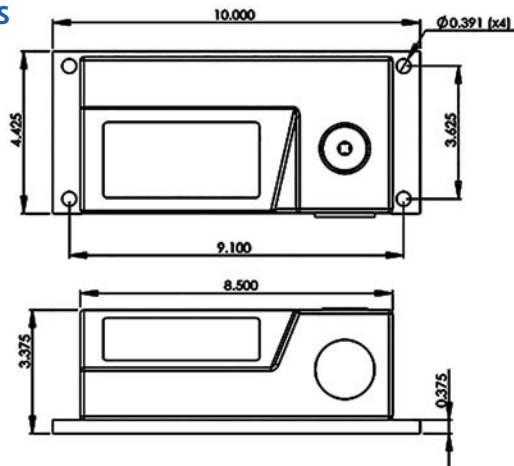

TT-QC Torque Tester

Low cost bench mount torque tester is perfect for quick equipment verification right at your workstation. Small and light enough to use anywhere, this unit can still be used alongside any metrology grade tester.



MTM Multi-Range Torque Tester

The MTM Series of torque transducers are designed to provide an economical way to measure and calibrate multiple torque tools. MTM models include an integrated display for a fully integrated tester.



CHECK•LINE® - PRECISION QUALITY CONTROL INSTRUMENTS

Electromatic Equipment Co., Inc.
600 Oakland Ave.
Cedarhurst, NY 11516 —USA

Tel: (800) 645-4330 (USA & Canada)
Tel: (516) 295-4300
Fax: (516) 295-4399

Email: info@checkline.com
Website: www.checkline.com

FOR ADDITIONAL INFORMATION OR TO PLACE AN ORDER CALL TOLL FREE 1-800-645-4330