

Optic Fiber TENSION SENSOR

Model TF

6 Tension Ranges

0–100 g up to 0–5.00 Kg

Large 70 mm aluminum rollers minimize bending of material which might damage or break the fragile filament.

The outer rollers are mounted on a movable plate to minimize contact when measurements are not being made.

Tension ranges of 10Kg and higher are available without moveable outer rollers.

Built-in signal conditioning with ZERO and SPAN pots provide a high-level, analog output to minimize the chance for signal interference.

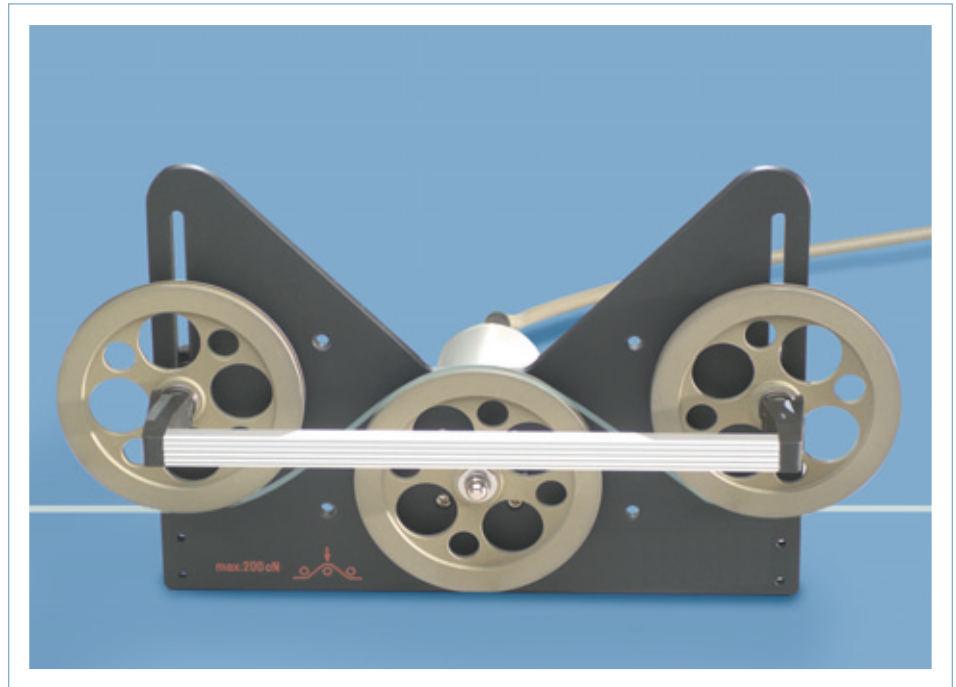

FEATURES

- 70mm V-grooved rollers are rated for speeds up to 5000 m / min
- Precision strain gauge sensing insures highest accuracy
- Frequency response of 100 Hz
- Surface mount electronics provide long-term reliability
- Optional roller types are available for a wide variety of material profiles
- Optional 5 ft. cable, TE-CABLE-CC is recommended. Longer lengths are available
- 0–1 V DC output, proportional to tension (0–10 V DC optional)

TENSION RANGES

Model #	TF-100	TF-200	TF-500	TF-1K	TF-2K	TF-5K
Range	0–100 g	0–200 g	0–500 g	0–1000 g	0–2000 g	0–5.00 Kg

Dimensions

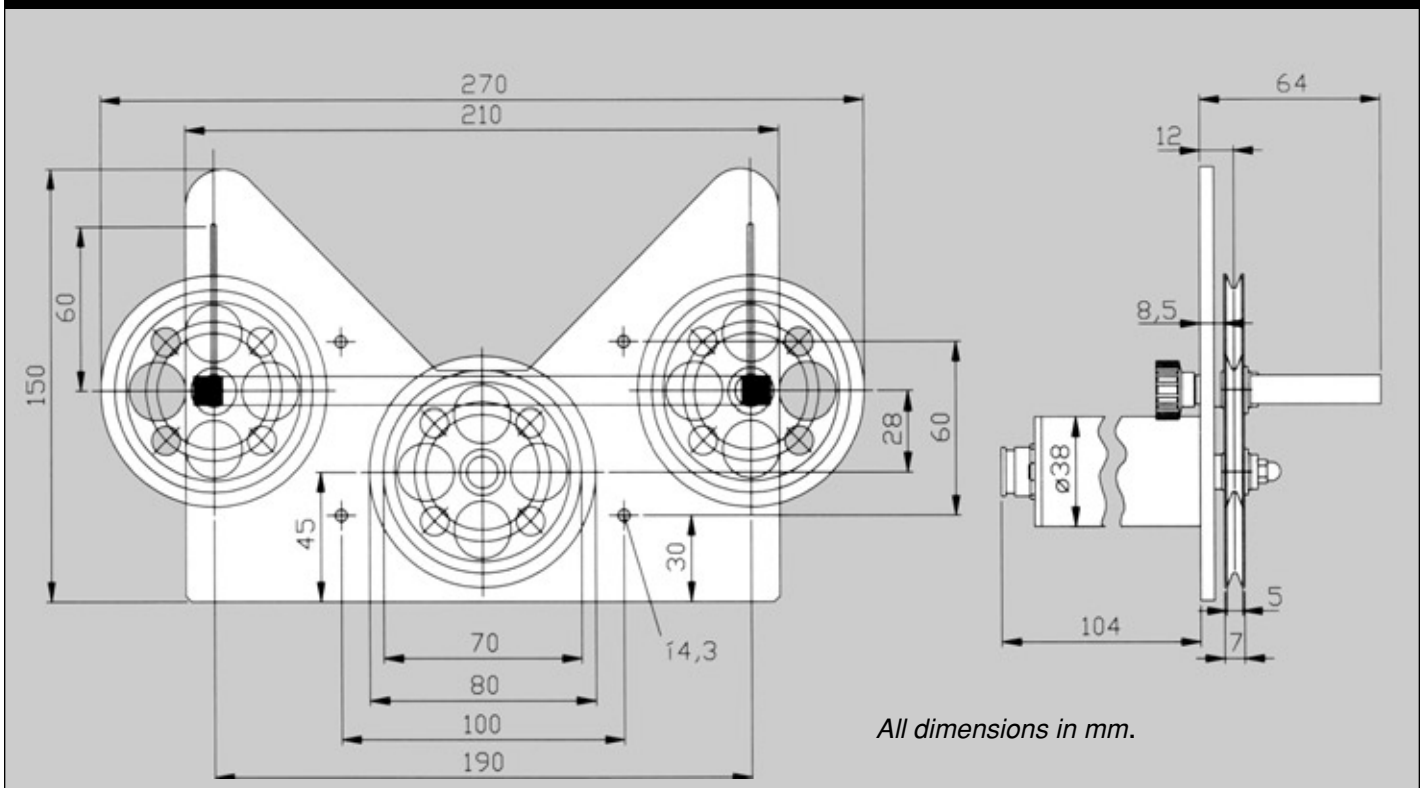

Specifications

Accuracy	±1.5% FS or better
Sensor Excitation	12–18 VDC, 21 mA
Middle Roller Deflection	0.5 mm (maximum)
Sensor Output	0–1 V DC (standard), 0–10 V DC (optional), proportional to tension
Overload Rating	150% FS
Housing Material	Aluminum

Spacing of Outer Rollers	190mm
Roller Diameter (Root)	70mm
Roller Material	Hard-Anodized Aluminum
Maximum Linear Speed	5000 m/min
Operating Temp.	40 to 105 °F (5–40 °C)

Specifications subject to change without notice.

CHECK•LINE® – PRECISION QUALITY CONTROL INSTRUMENTS

Electromatic Equipment Co., Inc.
600 Oakland Ave.
Cedarhurst, N Y 11516 —USA

Tel: (800) 645-4330 (USA & Canada)
Tel: (516) 295-4300
Fax: (516) 295-4399

Email: info@checkline.com
Website: www.checkline.com

FOR ADDITIONAL INFORMATION OR TO PLACE AN ORDER CALL TOLL FREE 1-800-645-4330