



NEW

CAP-T

Cap Torque Tester

- 3 Year Warranty
- Accepts samples up to 7.5" (189.4 mm) diameter
- Selectable units of measurement (lb-in, kg-mm, N-cm)
- Real time and peak mode (selectable)
- Both clockwise and counterclockwise operation
- Battery or AC operation
- Accuracy: $\pm 0.5\%$ of full scale ± 1 digit

The new CAP-T Cap Torque Tester accurately measures twist-off and twist-on force. The CAP-T is an ideal tester for bottlers, food and beverage companies, and others. The tester features a solid aluminum housing and rugged construction for many years of service in laboratory or production environments. Adjustable posts effectively grip a broad range of container shapes and sizes, while a set of optional jaws are available as an alternative gripping method. The CAP-T captures peak torque in both clockwise and counterclockwise directions for application and removal measurements.



Suitable for a wide range of container shapes and sizes, the CAP-T is an ideal tester for bottlers, food and beverage companies and others.

Specifications

Accuracy	± 0.5% of full scale, ±1 least significant digit
Sampling Rate	30 readings per second
Display	4-1/2 digit LCD with .3" high characters. Indicators for low battery, units and mode of operation
Power	Non-rechargeable 9V battery or AC operation with included adapter
Battery Life	30 hours of continuous use, LO BAT indicator
Overload Protection	150% or higher
Weight	10 lbs (4.5 kg)
Warranty	3 years
Calibration Certificate	Included

Torque Ranges

Model	Capacity	Resolution
CAP-T-12	12 lb-in	0.01 lb-in
	140 kg-mm	0.1 kg-mm
	135 N-cm	0.1 N-cm
CAP-T-50	50 lb-in	0.05 lb-in
	580 kg-mm	0.5 kg-mm
	570 N-cm	0.5 N-cm
CAP-T-100	100 lb-in	0.1 lb-in
	1,150 kg-mm	1 kg-mm
	1,150 N-cm	1 N-cm

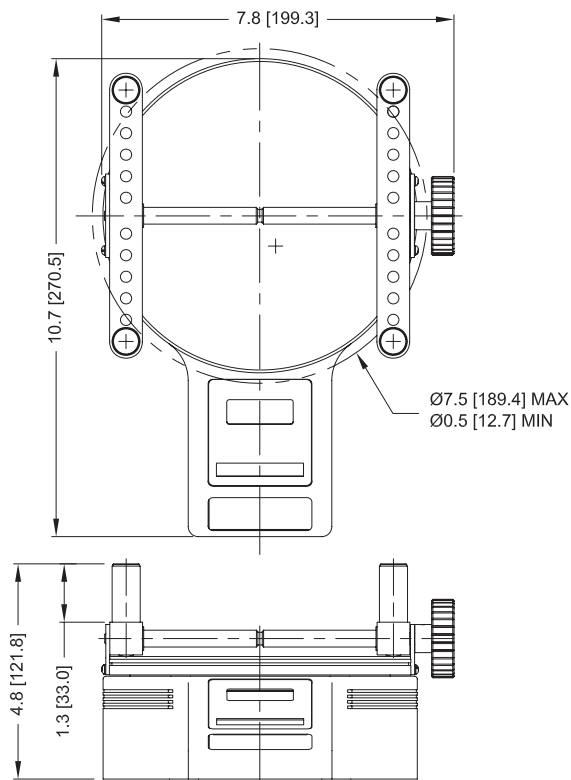

WITH OPTIONAL JAWS:

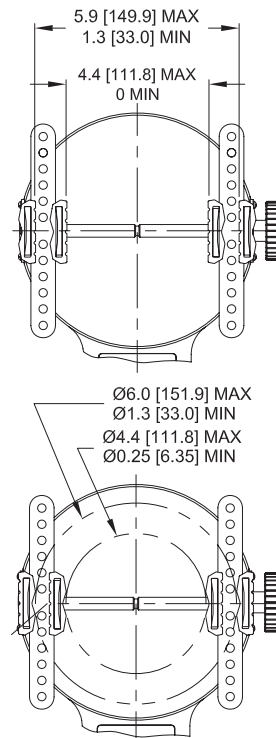

Moveable Posts.



Simple Hand Operation.



Optional Sample Gripping Jaws.



Optional Data Output Package.

CHECK·LINE® - PRECISION QUALITY CONTROL INSTRUMENTS

Electromatic Equipment Co., Inc.
600 Oakland Ave.
Cedarhurst, N Y 11516 —USA

Toll Free: (800) 645-4330 (USA & Canada)
Tel: (516) 295-4300
Fax: (516) 295-4399

Email: info@checkline.com
Website: www.checkline.com

FOR ADDITIONAL INFORMATION OR TO PLACE AN ORDER CALL TOLL FREE 1-800-645-4330