

The TSTM torque test stand is ideal for a wide variety of applications requiring up to 100 lbFin of torque, including closure torque testing, fastener torque testing, and more. Motorized clockwise and counterclockwise rotation allows for more precise and repeatable test results than with manual test stands. Modular design allows the stand to be configured for a variety of torque sensors and gripping fixtures while a lever-operated slider with travel stops makes engaging and disengaging samples quick and efficient. The stand includes a torque loading plate with tapped holes for grip and custom fixture mounting and an angle dial indicator with 2° resolution and unlimited angular travel.

Specifications

Load capacity:	100 lbFin [11.3 Nm]
Speed range:	0.3 - 8.6 RPM (4 - 52°/s)
Speed setting accuracy:	±5%, ±0% variation with load
Maximum angular travel:	No limit
Angular rate:	12° per hand wheel revolution
Angle indicator resolution:	2°
Maximum slider travel:	15.5 in [394 mm]
Slider travel rate:	1.047 in [26.6 mm] per lever revolution
Weight (w/o optional equipment):	
TSTM:	35.5 lb [16.1kg]
TSTMH:	29.5 lb [13.4 kg]
Included accessories:	Wrench set
Warranty:	3 years (see individual statement for further details)

>> Rotating torque plate has a matrix of tapped holes for grip or fixture mounting



Optional Equipment

Digital angle indicator TST001	Displays cw or ccw angle with 0.1° resolution for approximately 278 rotations, resettable with zero button. Accurate to ±0.7°. Three sets of mounting holes allow the indicator to be mounted perpendicular to, or parallel to the test stand column. It can also be repositioned along the column.
Torque sensor	Series STJ sensors are recommended for use with Mark-10 torque test stands. A wide range of capacities is available. Mounts directly to the test stand. Other sensors and mounting adapters are available.
Force/torque indicator BGI	Displays reading from the torque sensor. Includes features such as data outputs, data averaging, set points, and more.
Torque gauge Series MGT	Basic torque gauge for various applications.
Overload protection module 11-1042	Protects the torque sensor against overloads during motorized tests, adjustable from 10 - 150% of sensor's full capacity. Compatible with the the BGI.
Set point cable 09-1090	Stops test stand travel at programmable high and low set points for clockwise and counterclockwise torque. Compatible with the BGI.
Grips	Various universal and application-specific grips are available

>> Digital angle indicator



TSTM



The TSTM is shown in a cap torque test, with an STJ torque sensor, BGI force/torque indicator, and G1023 universal closure grip, and G1053 cap grip

TSTMH

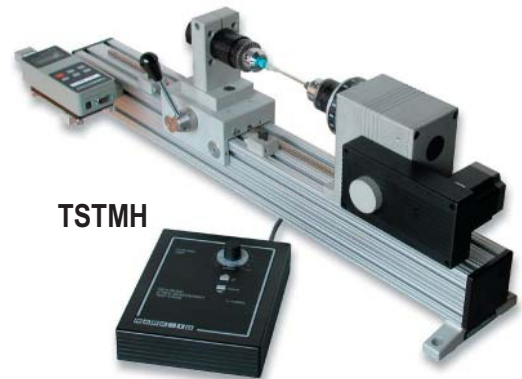

The TSTMH is shown in a pen cap torque test, with an STJ torque sensor, BGI force/torque indicator, and G1022 Jacobs chuck grip

Dimensions

in [mm]

TSTM

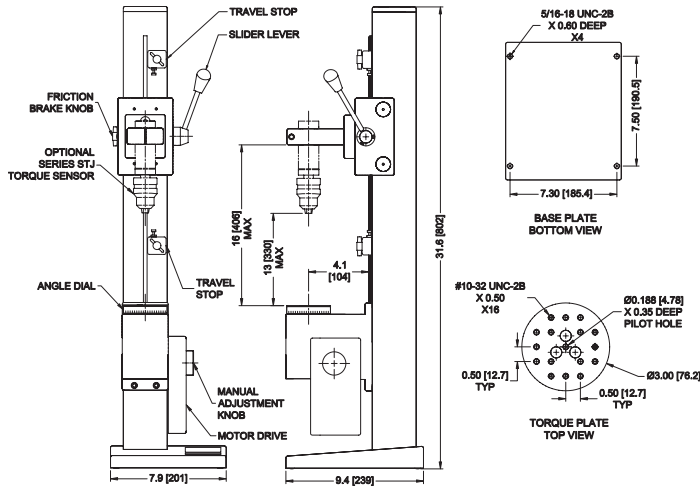

TSTMH

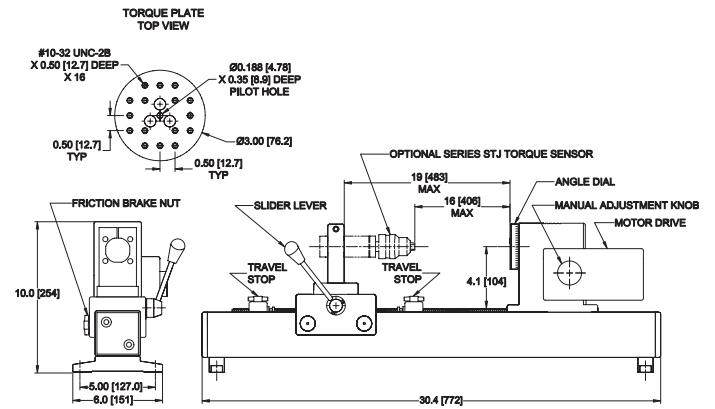

Ordering Information

Model No.	Description
TSTM ¹	Torque test stand, motorized, 100 lbFin, vertical, 110V
TSTMH ¹	Torque test stand, motorized, 100 lbFin, horizontal, 110V
TST001	Digital angle indicator
STJ ²	Universal torque sensor
BGI	Universal force/torque indicator
MGT ³	Digital torque gauge
11-1042	Overload protection module, BGI to test stand
09-1090	Set point cable, BGI to test stand

TST / TSTH test stands include a wrench set and AC1004 adjustable gauge mounting plate (for BGI or MGT).

1. For 220V operation, add suffix E to the model number. Example: TSTM E
2. Series STJ torque sensors are available in a wide range of capacities, from 10 ozin to 100 lbin (7 Ncm to 1150 Ncm), and mount to the TST / TSTH without extra adapters. Other sensors and mounting adapters are available.
3. Series MGT torque gauges are available in a wide range of capacities, from 10 ozin to 100 lbin (7 Ncm to 1150 Ncm), and mount to the TSTM / TSTMH without extra adapters.