

# Force Test Stands Series **TS**

---

MODELS TSA, TSAH, TSB, TSC & TSCH

## User's Guide

**Thanks!**

Thank you for purchasing a Mark-10 Series TS Force Measurement Test Stand. We are confident that you will get many years of service from this product.

Series TS Force Measurement Test Stands can be used in any number of compression and tension testing applications. To maintain smooth mechanical functioning of your test stand, avoid repetitive overloads and shock loads.

We hope that this User's Guide will provide a comprehensive explanation of the test stand's operation and sufficient detail on its specifications. However, if you have any questions or concerns our technical support and engineering teams will be eager to help you.

Thank you again for your purchase and happy testing!

**TABLE OF CONTENTS**

**UNPACKING AND SETTING UP** .....2

**LIST OF INCLUDED ITEMS** .....2

**OPERATION, SPECIFICATIONS, AND DIMENSIONS** .....3

    TSA / TSAH.....3

    TSB .....5

    TSC / TSCH .....7

**OTHER TEST STANDS BY MARK-10**..... 9

**FORCE GAUGES BY MARK-10** .....10

**WARRANTY** .....10

**FORCE GAUGES BY MARK-10**  
**Capacities from 0.25 lb (1 N) to 1,000 lb (5,000 N)**

**Force Gauges Series EG**



- Reversible aluminum housing for hand-held use or stand mounting
- Three units of measurement: lb, kg, N
- Programmable initial status of units and mode of operation
- Automatic peak memory
- Push-button calibration
- Battery or AC operation with programmable automatic shutoff
- Permanent configuration memory
- Optional RS-232, Mitutoyo and analog outputs

**Force Gauges Series BG / CG**  
 (in addition to EG features)



- Test up to 1,000 lb (5,000 N) of force (CG only)
- RS-232, Mitutoyo and analog outputs
- GCL – Gauge Control Language for full control of all functions
- Automatic timed output on RS-232
- Dual set points with outputs
- General purpose I/O for external device control
- Programmable analog and digital filters
- Averaging mode for obtaining average force readings over time



**Force Gauges Series MG**



- Low cost and small size
- Aluminum housing is reversible for hand-held use or test stand mounting
- Peak memory for tensile and compressive loads
- Selectable units of measurement programmable auto shutoff
- Push-button calibration
- IPM - Intelligent Power Management system for reliable operation

**WARRANTY**

Mark-10 Corporation expressly warrants to its buyer for three (3) years from the date of delivery that the goods sold are free from defects in workmanship and materials. Mark-10 Corporation will, at its option, repair or replace or refund the purchase price of goods found to be defective. This remedy shall be the buyer's sole and exclusive remedy. Any modification, abuse, exposure to corrosive environment or use other than intended will void this warranty. This warranty is in lieu of all other warranties, including implied warranties of merchantability and fitness for an intended purpose. In no event shall Mark-10 Corporation be liable for any incidental and consequential damages in connection with goods sold or any part thereof.

## OTHER TEST STANDS BY MARK-10



**ESM**  
Force, Motorized  
200 lb



**TSTM**  
Torque, Motorized  
100 lbin  
*Horizontal configuration  
also available (TSTMH)*

**TST**  
Torque, Hand Wheel  
100 lbin  
*Horizontal configuration  
also available (TSTH)*



**TSF**  
Force, Handwheel  
1,000 lb  
*Horizontal configuration  
also available (TSFH)*



**ES30**  
Force, Hand Wheel  
200 lb



**ES10**  
Force, Lever  
100 lb

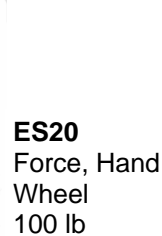

**ES20**  
Force, Hand  
Wheel  
100 lb

## UNPACKING AND SETTING-UP

1. Carefully unpack the stand and inspect for any damage. Check to make sure that you have received a complete test stand with all accessories – see the “List of included items” section below.
2. Install the loading lever on Models TSA, TSAH and TSB. The position of the loading lever can be adjusted as required – see the “Operation” section for your particular model. No assembly is required for Models TSC and TSCH.
3. Place the stand on a firm, flat and level working surface free from vibration to ensure accurate readings. It is recommended that the test stand be secured to a work bench – see the “Operation” section for your particular model.

## LIST OF INCLUDED ITEMS

Quantity	Item
1	Force measurement stand
4	#6-32 thumb screws for gauge mounting
4	#10-32 thumb screws (all models except TSB)
1	User's guide (this booklet)
1	Mounting hole drill template (all models except TSAH and TSCH)
1	Tool kit (all models except TSB)
1	Attachment kit (all models except TSB) - includes two hooks and a 2" diameter compression plate

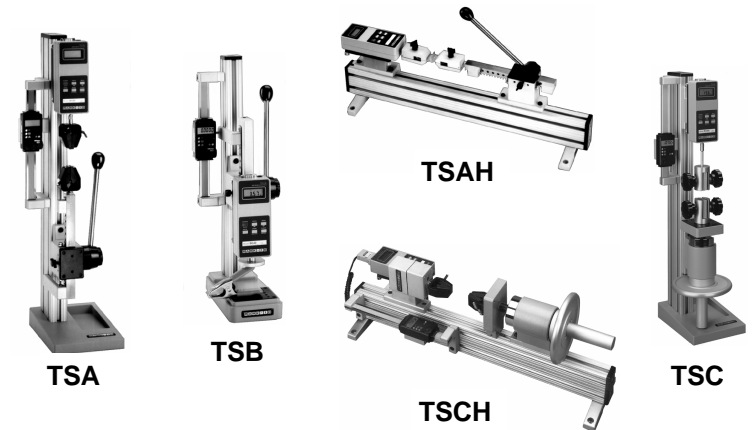

TSA

TSB

TSAH

TSCH

TSC

# TSA / TSAH

## OPERATION

1. Mount the test stand to a firm, flat, and level working surface for maximum safety and accuracy using four 5/16 screws (not included). Use the included mounting hole drill template to accurately drill the holes. Testing can take place without securing the test stand in such a manner, however, it is strongly recommended that the stand be secured, especially for large forces.
2. Install a force gauge onto the gauge plate with four thumb screws. Mark-10 force gauges mount directly to the stand without adapters.
3. Install any needed attachments, including grips, adapters, and other materials necessary for your test sample. Make sure these items are set up in a secure and safe manner.
4. Zero out the force gauge, then begin the test by turning the hand-wheel clockwise for compression or counter-clockwise for tension.

The loading lever can be adjusted to allow for ease of operation. Reposition the loading lever by removing the knob and realigning the lever pin in the mounting hub. Move the loading lever clockwise for compression, counter-clockwise for tension.

The rack brake can be set by loosening the wing nut, positioning the rack to the desired location and re-tightening the wing nut.

The clearance on the rack can be set by adjusting the four set screws using the tools provided.

The travel stops can be adjusted in 0.5" [12.7 mm] increments along the rack by moving the blocks to the desired location and tightening two screws. Fine adjustments can be made using adjusting screws on the housing and locking the jam nuts.

*Note:* To maintain smooth functioning of the stand, avoid overloads and repetitive shock loads.

### Optional Equipment

#### Digital Travel Display Kit – for accurate position indication

This position indicator covers 6" of travel per setting with a 5-digit display (0.0005" resolution) and a computer interface for automated data collection. It may be easily installed by the user.

# TSC / TSCH

## DIMENSIONS

In [mm]

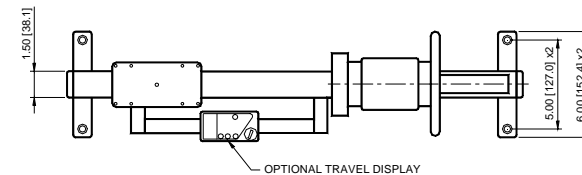
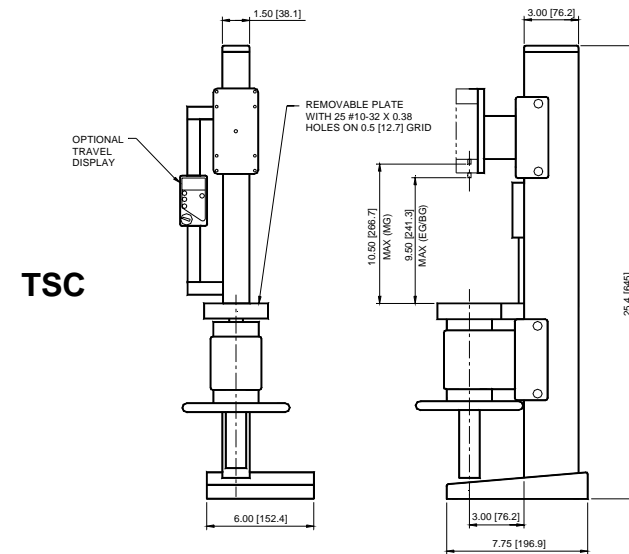

## TSCH

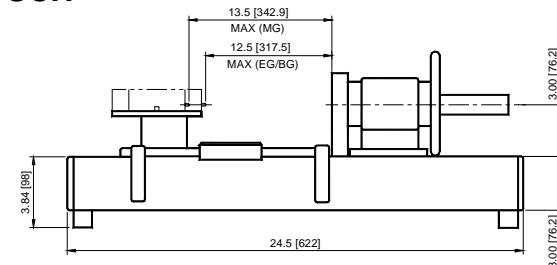

# TSC / TSCH

## OPERATION

1. Mount the test stand to a firm, flat, and level working surface for maximum safety and accuracy using four 5/16 screws (not included). Use the included mounting hole drill template to accurately drill the holes (TSC, only). Testing can take place without securing the test stand in such a manner, however, it is strongly recommended that the stand be secured, especially for large forces.
2. Install a force gauge onto the gauge plate with four thumb screws. Mark-10 force gauges mount directly to the stand without adapters.
3. Install any needed attachments, including grips, adapters, and other materials necessary for your test sample. Make sure these items are set up in a secure and safe manner.
4. Zero out the force gauge, then begin the test by turning the hand wheel clockwise for compression or counter-clockwise for tension.

*Note:* To maintain smooth functioning of the stand, avoid overloads and repetitive shock loads.

### Optional Equipment

#### Digital Travel Display Kit – for accurate position indication

This position indicator covers 6" of travel per setting with a 5-digit display (0.0005" resolution) and a computer interface for automated data collection. It may be easily installed by the user.

## SPECIFICATIONS

Load capacity	1000 lb [5000 N]
Maximum travel	3.5" [88.9 mm]
Loading method / rate	Handwheel 0.1" [2.54 mm] per rev.
Weight (test stand, only)	TSC: 25 lb [9.0 kg], TSCH: 20 lb [11.3 kg]
Digital travel display (optional)	Resolution: 0.0005" [0.01 mm]

# TSA / TSAH

## DIMENSIONS

In [mm]

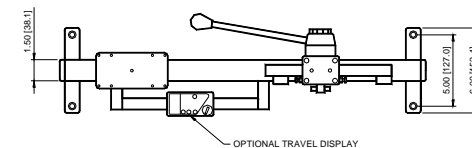
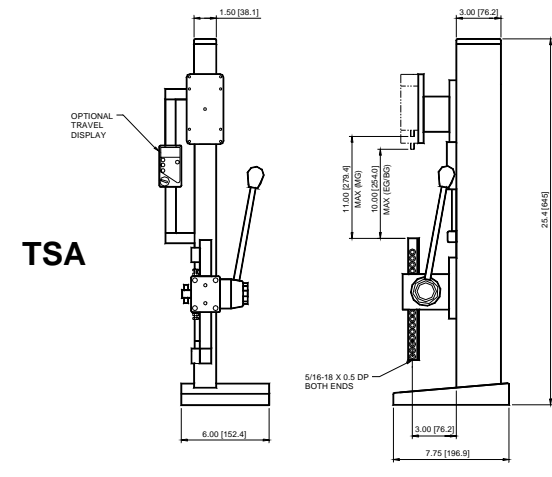

### TSAH

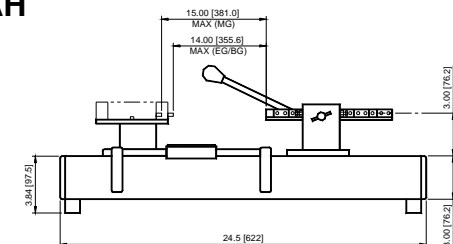

## SPECIFICATIONS

Load capacity	750 lb [3750 N]
Maximum travel	6" / 3.75" [152.4 mm / 95.3 mm], with stops
Loading method / rate	Rack & pinion / 3" [76.2 mm] per rev.
Weight (test stand, only)	TSA: 16 lb [7.3 kg], TSAH: 13 lb [5.9 kg]
Optional digital travel display resolution	0.0005" [0.01 mm]

# TSB

## OPERATION

1. Mount the test stand to a firm, flat, and level working surface for maximum safety and accuracy using four 5/16 screws (not included). Use the included mounting hole drill template to accurately drill the holes. Testing can take place without securing the test stand in such a manner, however, it is recommended that the stand be secured.
2. Install a force gauge onto the gauge plate with four thumb screws. Mark-10 force gauges mount directly to the stand without adapters.
3. Install any needed attachments, including grips, adapters, and other materials necessary for your test sample. Make sure these items are set up in a secure and safe manner.
4. Zero out the force gauge, then begin the test by turning the hand wheel clockwise for compression or counter-clockwise for tension.

The loading lever can be adjusted to allow for ease of operation. Reposition the loading lever by removing the knob and realigning the lever pin in the mounting hub. Move the loading lever clockwise for compression, counter-clockwise for tension.

The rack brake can be set by loosening the wing nut, positioning the rack to the desired location and re-tightening the wing nut.

The clearance on the rack can be adjusted by removing the gauge plate, aligning the C-bracket holes with the set screws and adjusting as necessary.

*Note:* To maintain smooth functioning of the stand, avoid overloads and repetitive shock loads.

### Optional Equipment

#### Digital Travel Display Kit – for accurate position indication

This position indicator covers 6" of travel per setting with a 5-digit display (0.0005" resolution) and a computer interface for automated data collection. It may be easily installed by the user.

# TSB

## DIMENSIONS

In [mm]

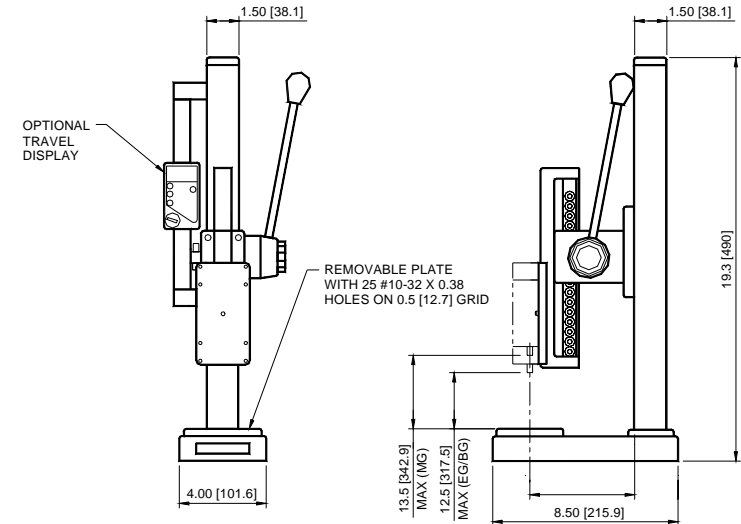

## SPECIFICATIONS

Load capacity	100 lb [500 N]
Maximum travel	6" / 3.75" with stops [152.4 mm / 95.3 mm]
Loading method / rate	Rack & pinion 3" [76.2 mm] per rev.
Weight (test stand, only)	12 lb [5.4 kg]
Optional digital travel display resolution	0.0005" [0.01 mm]