9.0 WARRANTY

The manufacturer warrants to the original purchaser that this product is of merchantable quality and confirms in kind and quality with the descriptions and specifications thereof. Product failure or malfunction arising out of any defect in workmanship or material in the product existing at the time of delivery thereof which manifests itself within one year from the sale of such product, shall be remedied by repair or replacement of such product, at the manufacturer's option, except where unauthorized repair, disassembly, tampering, abuse or misapplication has taken place, as determined by the manufacturer. All returns for warranty or non-warranty repairs and/or replacement must be authorized by the manufacturer, in advance, with all repacking and shipping expenses to the address below to be borne by the purchaser.

THE FOREGOING WARRANTY IS IN LIEU OF ALL OTHER WARRANTIES, EXPRESSED OR IMPLIED, INCLUDING BUT NOT LIMITED TO, THE WARRANTY OF MERCHANTABILITY AND FITNESS FOR ANY PARTICULAR PURPOSE OR APPLICATION. ELECTROMATIC SHALL NOT BE RESPONSIBLE NOR LIABLE FOR ANY CONSEQUENTIAL DAMAGE, OF ANY KIND OR NATURE, RESULTING FROM THE USE OF SUPPLIED EQUIPMENT, WHETHER SUCH DAMAGE OCCURS OR IS DISCOVERED BEFORE, UPON OR AFTER REPLACEMENT OR REPAIR, AND WHETHER OR NOT SUCH DAMAGE IS CAUSED BY MANUFACTURER'S OR SUPPLIER'S NEGLIGENCE WITHIN ONE YEAR FROM INVOICE DATE.

Some State jurisdictions or States do not allow the exclusion or limitation of incidental or consequential damages, so the above limitation may not apply to you. The duration of any implied warranty, including, without limitation, fitness for any particular purpose and merchantability with respect to this product, is limited to the duration of the foregoing warranty. Some states do not allow limitations on how long an implied warranty lasts but, notwithstanding, this warranty, in the absence of such limitations, shall extend for one year from the date of invoice.

Every precaution has been taken in the preparation of this manual. The manufacturer, assumes no responsibility for errors or omissions. Neither is any liability assumed for damages resulting from the use of information contained herein. Any brand or product names mentioned herein are used for identification purposes only, and are trademarks or registered trademarks of their respective holders.

TABLE OF CONTENTS

1.0	Introduction	2
2.0	Unpacking and Setup	3
3.0	Installing Batteries	4
4.0	Overview	4
5.0	Using Indicator Function Keys	5
6.0	Operating Procedures	7
	6.1 Checking Thick Materials	
	6.2 Data Port	
7.0	Accessories	9
8.0	Specifications and Dimensions	11
9.0	Warranty	12

1.0 INTRODUCTION

The Model MTG benchtop contact thickness gauge accurately and conveniently performs geometric dimensional testing (thickness measurement) on rubber, fabrics, foams, tapes/films and a wide assortment of other soft materials. It employs a specified presser foot (feeler) of a specific diameter/area, combined with a predetermined mass (weight) as noted in the ASTM D 3767 standard.

The MTG system is supplied with a unique air damping feature which ensures that the presser foot descends at the same rate for each test. This eliminates human error resulting in superior repeatability. If required, the rate of descent can be user-adjusted.

For those requiring data output for recording and quality documentation purposes, a serial output cable and Windows-based software program is optionally available.

8.0 SPECIFICATIONS AND DIMENSIONS

Certified Electronic Indicator

<i>Range</i>	0–1" (0–25mm)
<i>Resolution</i>	.0001" (0.001mm)
<i>Power</i>	CR 2450 Lithium batteries (2)

Units

Inch or metric
Operator selectable

Data Output

RS-232, Mitutoyo (MTI) , BCD

Certified Granite Base

6" x 6" x 2" (152.4 x 152.4 x 50.8mm)
Grade AA

Presser Foot

0.63" (16mm)

Mass (Weight)

6.82 oz (212 g)

Lifting Lever

left hand

Maximum Height

5 inches

Warranty

1 year

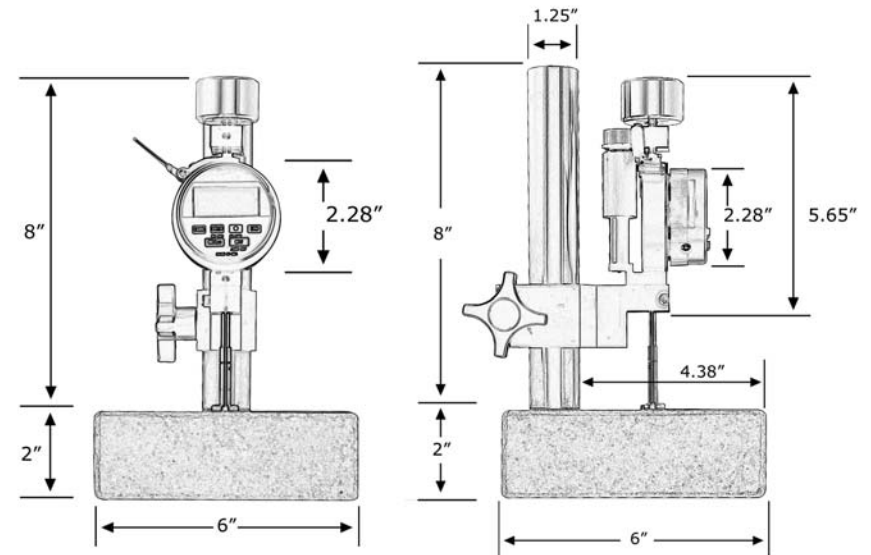

Optional Presser Foot (Feeler / Anvil)	
Presser Foot "A"	Dim. (mm)
PF-1	10.0
PF-2	8.0
PF-3	6.3
PF-4	6.0
PF-5	5.0
PF-6	4.0
PF-7	3.2
PF-8	16.0
PF-9	25.0

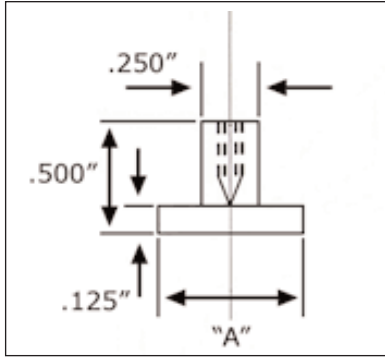

2.0 UNPACKING AND SET-UP

Your MTG system is packaged completely assembled and tested at our plant to ensure a quality product. However, there are some basic steps that must be performed before using your MTG for the first time.

1. Carefully unpack the MTG. Take special care when lifting to support the unit from the granite base when unpacking and whenever moving the unit.
2. If additional presser feet and weights (mass) have been ordered be sure to also unpack those items, which are wrapped separately.
3. After the unit is unpacked, it can be cleaned with alcohol, **WITH EXCEPTION OF THE ELECTRONIC INDICATOR.**
4. The MTG should then be placed on a clean, flat vibration-free surface for use.

3.0 INSTALLING BATTERIES

1. Using a narrow edge, flathead screwdriver, gently pry under the tab on the left side of the indicator bezel and slide out the battery tray as you turn the indicator face down.
2. Insert two CR 2450 Lithium batteries (3V) into the tray cavities, positive (+) side up. Now slide the tray back into its slot, taking care that the batteries stay in proper position.



4.0 OVERVIEW

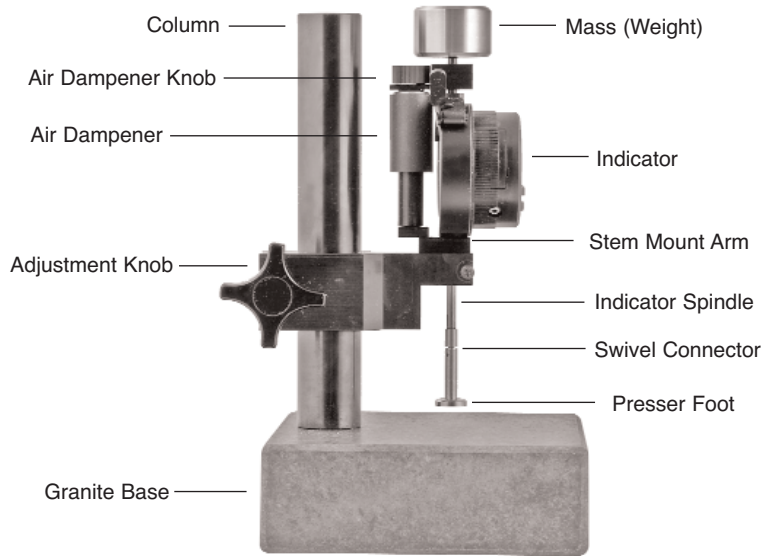

Lifting Arm



Function Keys

7.0 ACCESSORIES

The MTG can be used to check the thickness of rubber and rubber type materials. Use the optional presser feet and mass combinations to check a wide assortment of other materials, such as foams, tapes, films, textiles, felts, sheetmetal, foils, fabrics, cloth, leather, fiberboard, plywood, paper, etc.

For Materials Equal to or Above 35 IRHD

Presser Foot/Mass Combinations			
Foot Model	Foot Dia. (mm)	Mass Model	Mass (g)
MTG-01-1	10.0	MTG-03-1	176
MTG-01-2	8.0	MTG-03-2	113
MTG-01-3	6.3	MTG-03-3	70
MTG-01-4	6.0	MTG-03-4	63
MTG-01-5	5.0	MTG-03-5	44
MTG-01-6	4.0	MTG-03-6	28
MTG-01-7	3.2	MTG-03-7	18
MTG-01-8 1	6.0	MTG-03-8	452
MTG-01-9	25.0	MTG-03-9	1104

For Materials Below 35 IRHD

Presser Foot/Mass Combinations			
Foot Model	Foot Dia. (mm)	Mass Model	Mass (g)
MTG-01-1	10.0	MTG-04-1	80
MTG-01-2	8.0	MTG-04-2	52
MTG-01-3	6.3	MTG-04-3	32
MTG-01-4	6.0	MTG-04-4	29
MTG-01-5	5.0	MTG-04-5	20
MTG-01-6	4.0	MTG-04-6	13
MTG-01-7	3.2	MTG-04-7	8
MTG-01-8 1	6.0	MTG-04-8	212
MTG-01-9	25.0	MTG-04-9	518

Note: Custom sized presser feet and weights (mass) to fit specific needs or applications are also available.

6.1 Checking Thick Materials

For checking materials over 1 inch in thickness, use precision ground gage blocks in conjunction with the MTG.

Example: If you are checking a 2 inch thick part you can use a 1 inch gage block positioned under the sample to obtain the thickness values.

The maximum sample height capacity of the MTG is 5 inches.

6.2 Data Port

For those requiring data output for recording and quality documentation purposes, a serial output cable and Windows-based software program is optionally available.



5.0 USING THE INDICATOR FUNCTION KEYS

To turn the indicator ON.

1. Press and hold the **ON/clr** key until **clr** appears on the indicator display, then release



To turn the indicator OFF.

1. Press and release the **OFF** key

To clear the indicator display to zero.

1. Press and release **ON/clr** key until **.0000** appears on the display.

To turn MAX HOLD on and off.

1. Press and release the **HOLD** key. **MAX** will appear on the screen when this function is active. Repeat to turn this function off.

To change the indicator units from inch to millimeter or millimeter to inch.

1. Press and hold **2nd** key until **2nd** appears on bottom of display, then release.
2. The newly selected units will appear at the bottom of the display. MM for millimeter or IN for inch.
3. Press and release "**•**" within three seconds to lock your selected units.

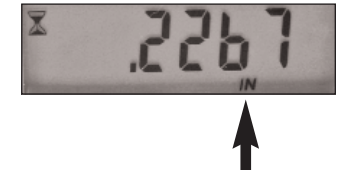

To turn AUTO OFF on and off

1. Press and hold **2nd** key until **2nd** appears on bottom of display, then release.
2. Press and release the **OFF** key within three seconds to activate your selection. An hourglass will appear on the left side of the display when the **AUTO OFF** feature is active



NOTE: **AUTO OFF** is activated after 10 minutes of non-use.

To Clear All Settings And Return To Factory Set Defaults:

1. Press and hold **2nd** until **2nd** appears on bottom of display and then release.
2. Press and release the **ON/cfr** key within three seconds.
3. Press and release the **CHNG** key within three seconds.

6.0 OPERATING PROCEDURES

The MTG system can be used to check the thickness of rubber and rubber type materials.

Note: The MTG System is supplied with a 16mm diameter presser foot and 212 gram mass. This configuration is commonly used for measurement of all rubber materials with a hardness of 35 IRHD or below

Optional presser feet and mass combinations are available to check a wide assortment of other material such as: foams, tapes, films, textiles, felts, sheet metal, foils, fabrics, cloth, leather, fiberboard, plywood, paper, etc.

1. Use the **Adjustment Knob** to position the Indicator so that the presser foot is resting freely on the granite base.
2. Clear indicator display to zero by pressing and releasing the **ON/cfr** key.
3. Use the **Lifting Lever** mechanism to raise the presser foot.
4. Place the material to be tested under the **Presser Foot** and release the lifting lever.



Note: Your MTG system is supplied with a unique air-dampening feature that controls the rate of descent of the presser foot. This allows the presser foot to descend at the same rate for each test, thus eliminating human error resulting in superior repeatability.

5. If required, the rate of descent can be user-adjusted by carefully turning the knurled knob located at the top of the air dampener (turn clockwise to slow the rate, counter-clockwise to speed up the rate). Care should be taken to not over adjust the dampener by over-rotating the adjustment knob.
6. Read and record the thickness of the material immediately after the presser foot makes full contact with the material.

Note: The pressure being applied by the instrument has a significant effect on the results obtained. The weight (mass) and presser foot diameter should be specified.

MATERIAL THICKNESS GAUGE

Model MTG-D



O P E R A T I N G M A N U A L



ELECTROMATIC
EQUIPMENT CO., INC.

600 Oakland Ave., Cedarhurst, NY 11516-U.S.A.
TEL: 516-295-4300 • FAX: 516-295-4399