



BM SERIES

Biomass Moisture Content Meters

- **BM1** - standard model.
 - **BM2** - with USB data output.
 - **BM2-KIT** - BM2 model bundled with scale.
-
- Automatic self-calibration ensures reliable and repeatable measurement results.
-
- Take measurement in seconds without prior treatment of samples.
-
- Bulk density compensation, using an electronic balance, for highest accuracy.
-
- Large backlit LCD display with over-sized numbers makes for easy viewing.
-
- Gauge menus in English, German, French, Italian, Spanish and Russian.
-
- BM2 includes datalogger for data transfer to PC or printer documenting moisture measurements, date, batch & temperature.
-
- Calibration certificates provided for both BM2 and Precision Scale at no extra cost.
-
- Includes built-in temp probe for automatic temperature compensation for highest accuracy under all conditions.
-
- 2-year warranty.



BM Series Biomass Moisture Meters quickly determine the water content of wood chips, barks, pellets, elephant grass, wood shavings and sawdust.

To operate simply turn on the gauge, collect the desired biomass test sample and pour it into storage bin, then view the water content (%-moisture) on the large, backlit, LCD display.

All models include a built-in datalogger for storage of up to 10,000 values. The BM2 includes a serial output for downloading stored data to an external printer, PC-Software or 3rd-Party accounting programs and is supplied with PC-Software, Transfer Cable and USB Converter at no additional cost.



All models are supplied with 3-1/2 gallon (13 liter) plastic bucket for collecting test samples. The rugged stainless steel storage bin (shown above) is integrated with gauge providing an all-in-one measuring system.

Specifications

Measuring range	5 to 60% water content depending on material type
Resolution	Water Content (0.5%) Temperature (0.5 °C or °F)
Accuracy	+/- 1.5%
Principle	Capacitance
Sample volume	13 liters (approx. 3.5 gal)
Menu languages	English, German, French, Italian, Spanish and Russian
Gauge housing	Plastic with IP40 rating
Storage bin	Stainless Steel
Display	Graphic LCD display with backlight (128 x 64 pixel)
Bulk Density Compensation	With HM-11656 Precision Scale

Temp compensation	Automatic in °C or °F using built-in temperature probe
Datalogger	10,000 moisture measurements plus date, batch & temperature
Data interface (BM2 only)	RS-232, 9600/8/N/1 (supplied with transfer cable & USB converter)
Operating temp	32°F to 104 °F (0 °C to 40 °C)
Storage temp	-4 °F to 140 °F (-20 °C to 60 °C)
Power	4 x 1.5 Volt AA Alkaline batteries
Battery life	900 measurements (with auto-off after 6 minutes of non-use)
Dimensions	19.3" x 11.4 x 11.8 (487 x 278 x 301mm)
Weight	11.60 lbs. (5.3 kg)

Complete Kit

The BM Series Biomass moisture meter is delivered as a complete kit including:

- BM Biomass Moisture Meter with integrated metal bin.
- Plastic bucket.
- 4 AA batteries.
- Operating manual.
- Data transfer cable, USB converter and software—BM2 only.

Scale is supplied in BM2-KIT version only. Delivery includes:

- Digital scale (10.00 Kg).
- Batteries.
- 115 VAC power supply unit.



Dimensions (in mm)

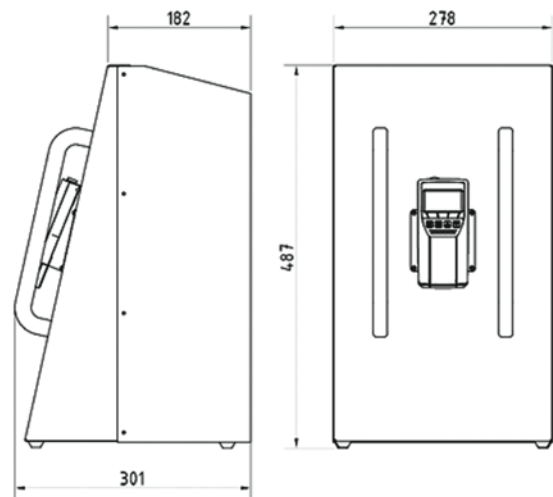

Specifications subject to change without notice.

CHECK•LINE®—PRECISION QUALITY CONTROL INSTRUMENTS

Electromatic Equipment Co., Inc.
600 Oakland Ave.
Cedarhurst, NY 11516 —USA

Tel: (800) 645-4330 (USA & Canada)
Tel: (516) 295-4300
Fax: (516) 295-4399

Email: info@checkline.com
Website: www.checkline.com

For additional information or to place an order CALL TOLL FREE 1-800-645-4330

Check•Line is a registered trademark of Electromatic Equipment Company Inc.