

PRECISION QUALITY CONTROL INSTRUMENTS SINCE 1958



# Combination Contact And Non-Contact Tachometer DT-200LR Series

## Models

### DT-205LR

LCD model with 6" circumference measuring wheel.

### DT-207LR

LED model with 6" circumference measuring wheel.

### DT-205LR-12

LCD model with 12" circumference measuring wheel.

### DT-207LR-12

LED model with 12" circumference measuring wheel.

## Features

- High-precision laser measures from distances up to 14 feet.
- Includes traceable calibration certificate.
- Built-in memory for last, maximum, minimum and 10 separate readings.
- DT-200 Series gauges are supplied as a complete kit (see page 2).

The CHECK-LINE DT-205LR & DT-207LR combine the best features found in both contact and non-contact tachometers for accurate measurement of rpm, surface speed and length.

DT-200LR models feature an improved laser dot that is brighter and smaller than the previous model allowing use on a smaller "target" (reflective tape) and for measurement from greater distances. The screw-in contact adapter makes it quick & easy to convert from non-contact to contact operation.



DT-200LR Series gauges are supplied as a complete kit, details on side 2.

# DT-200LR Series

<b>Measuring Range</b>	Non-Contact: 6 to 99,999 rpm Contact: 0.8 to 25,000 rpm
<b>Accuracy</b>	6 to 8,299 rpm: ±1 rpm 8,300 to 24,999 rpm: ±2 rpm 25,000 to 99,999 rpm: ±0.006% rpm
<b>Display</b>	LCD model: 5 digit 0.47" (12mm) high LED model: 5 digit 0.4" (10mm) high
<b>Measuring Units per Minute</b>	Revolutions, meters, yards, feet, inches
<b>Total Length</b>	Meters, yards, feet, inches
<b>Measuring Distance</b>	14 feet (5.2 m) maximum
<b>Detection</b>	Laser Diode, Class II
<b>Memory</b>	13 readings are stored in memory and retained for 5 minutes (last, max., min., and 10 measurements)
<b>Over-Range Indicator</b>	Flashing numerals
<b>Update Time</b>	1 second (typical)
<b>Batteries</b>	Two 1.5 V AA
<b>Battery Life</b>	DT-205LR approx 40 hrs DT-207LR approx 25 hrs
<b>Operating Temp</b>	32° to 113° F (0 to 45° C)
<b>Construction</b>	Die-cast aluminum housing
<b>Weight</b>	0.8 lbs (365 g)
<b>Dimensions</b>	6.6" L x 2.4" W x 1.8" H (167mm x 61mm x 45.7)
<b>Warranty</b>	1 year
<b>Accessories Included</b>	Reflective tape, cone adapter, surface speed wheel DT-ADP-200LR contact adapter and carrying case

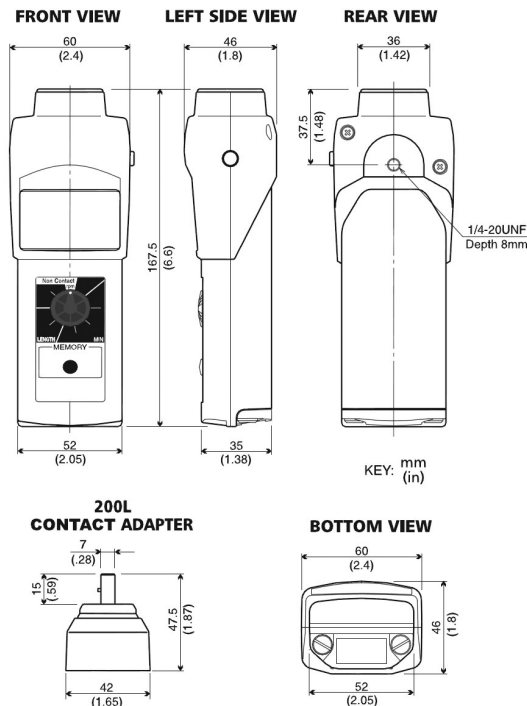

## LCD Display (DT-205LR)



Use LCD models in bright sunlight and for longest battery life.

## LED Display (DT-207LR)



Use LED models in dark or poorly lit environments.

## Accessories



Cone Tip  
Item # DTCA



Funnel Tip  
Item # DTFA



12" Measuring Wheel  
Item # LMA-3



6" Measuring Wheel  
Item # DT6



12" Measuring Wheel  
Item # DT12



Reflective Tape  
Item # 205T

## Complete Kit



All models are supplied as a complete kit including the tachometer, reflective tape, screw-in contact adapter, two cone tips, funnel tip, shaft extension, surface speed wheel, two AA batteries and an operating instruction manual—all supplied in a foam-fitted carrying case.



**For additional information or to place an order CALL TOLL FREE 1-800-645-4330**

**Electromatic Equipment Co., Inc.**  
600 Oakland Ave.  
Cedarhurst, N Y 11516 —USA

**Tel:** (800) 645-4330 (USA & Canada)  
**Tel:** (516) 295-4300  
**Fax:** (516) 295-4399

**Email:** info@checkline.com  
**Website:** www.checkline.com